

## **Air & Dirt Elimination in Hydronic Systems**



# **CALEFFI**



A Technical Journal  
from  
Caleffi Hydronic Solutions

**CALEFFI NORTH AMERICA, INC**  
9850 South 54th Street  
Franklin, Wisconsin 53132 USA

Tel: 414.421.1000  
FAX: 414.421.2878

E-mail: [idonics@caleffi.com](mailto:idonics@caleffi.com)  
Website: [www.caleffi.us](http://www.caleffi.us)

© Copyright 2007  
Caleffi North America, Inc.

Printed:  
Milwaukee, Wisconsin USA



Caleffi North America, Inc.  
9850 South 54th Street  
Franklin, WI 53132  
T: 414.421.1000 F: 414.421.2878

Dear Hydronic Professional,

Welcome to the 2<sup>nd</sup> edition of *idonics* – Caleffi's semi-annual design journal for hydronic professionals.

The 1<sup>st</sup> edition of *idonics* was released in January 2007 and distributed to over 80,000 people in North America. It focused on the topic hydraulic separation. From the feedback received, it's evident we attained our goal of explaining the benefits and proper application of this modern design technique for hydronic systems.

If you haven't yet received a copy of *idonics* #1, you can do so by sending in the attached reader response card, or by registering online at [www.caleffi.us](http://www.caleffi.us). The publication will be mailed to you free of charge. You can also download the complete journal as a PDF file from our Web site.

This second edition addresses air and dirt in hydronic systems. Though not a new topic to our industry, the use of modern high-efficiency equipment demands a thorough understanding of the harmful effects of air and dirt, as well as knowledge on how to eliminate them. Doing so helps ensure the systems you design will operate at peak efficiency and provide long trouble-free service.

We trust you will find this issue of *idonics* a useful educational tool and a handy reference for your future hydronic system designs. We also encourage you to send us feedback on this issue of *idonics* using the attached reader response card or by e-mailing us at [idonics@caleffi.com](mailto:idonics@caleffi.com).

Sincerely,

Mark Olson  
General Manager,  
Caleffi North America, Inc.

## INDEX

- 4 As old as hydronics
- 5 Air-related problems
- 7 Forms of entrapped air
- 9 Air removal devices
- 12 Placement of central air separators
- 13 Dirt separation
- 13 Dirt-related problems
- 14 Dirt separation methods
- 15 Efficiency of dirt separation
- 16 Placement of dirt separators
- 18 Combined air & dirt separators
- 18 Filling & purging hydronic systems
- 23 Diagnosing and correcting air-related problems
- 25 Summary
- 26 Appendix
- 27 Air separation products technical specifications
- 29 Dirt separation products technical specifications
- 31 Combination air/dirt separator products technical specifications

# AIR & DIRT ELIMINATION IN HYDRONIC SYSTEMS

## Welcome.

This issue of idronics discusses elimination of air and dirt from hydronic systems. Although both air and dirt can create similar problems, such as inadequate flow or poor heat transfer, they both have unique characteristics that are best examined individually at first. Then, total system solutions that address both air and dirt elimination will be shown.

## AS OLD AS HYDRONICS:

Air control within hydronic heating systems has always presented challenges. It began with the earliest hydronic systems that did not have circulators. Water flow was created by the buoyancy difference between hot water leaving the boiler and cooler water returning from the

heat emitters. These systems used large diameter piping and operated at very low flow velocities. Air removal was mostly a matter of waiting for air pockets to form and then releasing this air through manually operated valves that were (hopefully) located where the air accumulated.

Most of these early systems were “open-loop” rather than closed-loop systems. An expansion tank was often located at the high point of the system and vented to the atmosphere. Although air could leave this tank as the water in the system was heated and expanded, it could also reenter the tank as the water cooled. This allowed a constant presence of dissolved oxygen molecules within the water and provided a source of steady internal corrosion. Occupants simply accepted the fact that noises caused by entrapped air and the continuing need to “bleed” the system of air were just part of living with a hot water heating system.

During the 1940s, engineers began designing “closed-loop” hydronic systems along with new hardware to help capture air and separate it from the circulating water. Although some of the devices developed at the time, such as the boiler fitting shown in figure 1, are still in service today, they do not represent state-of-the-art technology.

Even when closed-loop hydronic systems became standard, industry veterans could attest that air elimination, especially during system commissioning, often remained a challenge. Many frustrating hours went into ridding systems of air, especially in large, complex piping systems. Keeping the air out of those systems also required frequent attention.

Part of the reason for this is that “closed-loop” hydronic systems are not 100 percent sealed against air entry. Although such systems appear to hold pressure reasonably well for months, and seldom have visible water leaks, they are not perfectly sealed. Small amounts of the gases that make up air can enter closed-loop hydronic systems in a variety of ways, especially if the system is poorly designed. Examples include air weepage at valve packings and circulator flange gaskets, as well as molecular oxygen diffusion directly through the walls of PEX or other types of polymer tubing. Air can even be pulled into systems through devices intended to *expel* it when improper design or maintenance allows internal pressure to drop below atmospheric pressure.

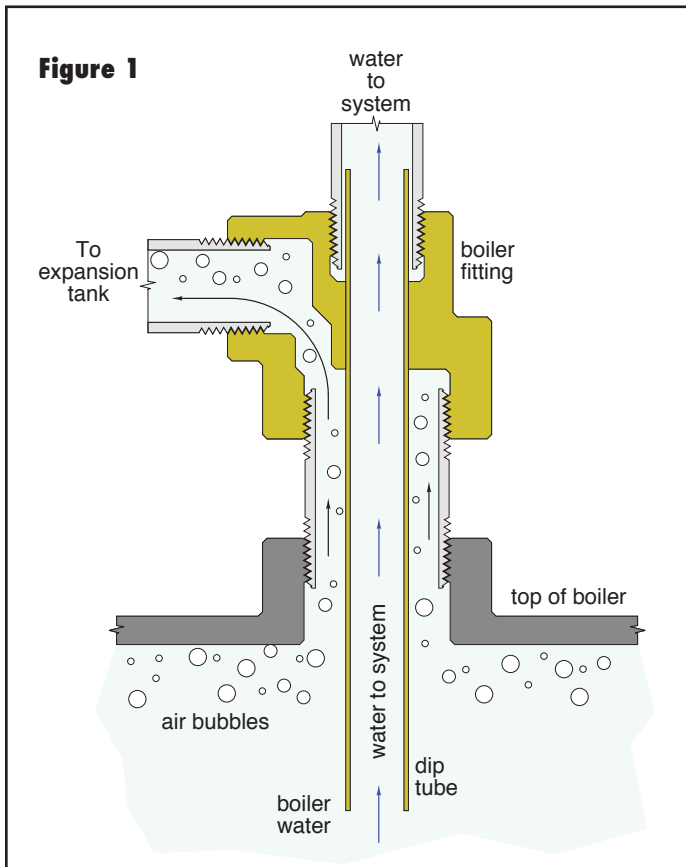



## AIR-RELATED PROBLEMS:

Problems due to air in hydronic systems can be frustrating to occupants as well as heating professionals. If these problems are not fully understood, the attempted solution often produces only temporary correction. Eventually those attempting to remedy chronic air problems may give up, thinking that the system is simply incapable of operating air-free. This is both unfortunate and unnecessary. *Modern hydronic systems can be designed to quickly and permanently eliminate air.*

Before discussing solutions, it's important to understand the problems that air can create in hydronic systems. They include:

- Noises in piping and heat emitters that annoy occupants
- Inadequate flows due to a mixture of water and air in circulators
- Poor heat transfer by heat emitters when all heat transfer surfaces are not wetted
- Accelerated corrosion due to oxygen in contact with ferrous metals
- Improper lubrication of circulator bushings due to air in flow
- Improper performance of balancing valves
- Complete loss of flow and heat output due to large air pockets

Let's examine each of these air-related problems in more detail.

**Noise:** A key benefit provided by a properly designed and installed hydronic system is silent conveyance comfort. Occupants should not hear flow as it travels through tubing and heat emitters. Properly deaerated water traveling through piping at velocities of 4 feet per second or less makes very little (essentially unnoticeable) sound. However, a mixture of water and air is much more acoustically active. Entrapped air sounds tend to be more noticeable when flow begins in a circuit due to disturbance of stationary air pockets. Air-filled cavities within piping and radiators act as acoustic amplifying chambers, especially if the water level in the device is below the level of the incoming water, in which case a "water fall" effect is heard. Noise is also generated when dissolved gases within water are released due to a sudden drop in pressure. This is called gaseous cavitation, and it often occurs in the orifice of valves.

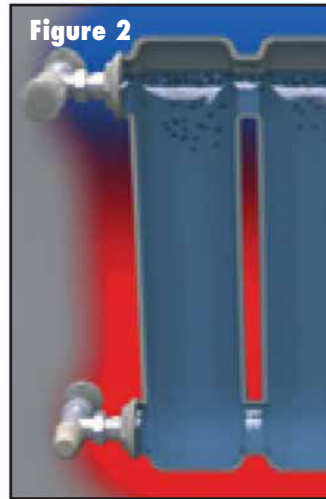

**Poor Heat Transfer:** Air has much lower convective heat transfer properties than water. When air displaces water away from heat transfer surfaces within boilers or heat emitters, the rate of heat transfer can be significantly reduced. In some cases, "cold spots" on radiators are indicative of entrapped air, as shown in figure 2.

**Accelerated Corrosion:** Air contains oxygen, and oxygen in contact with ferrous metals causes corrosion. Hydronic systems with chronic air problems are constantly resupplying oxygen into the system, which allows oxidation to occur at several times the rate experienced in a properly deaerated system.

The following chemical reactions can occur in hydronic systems containing ferrous (iron-containing) components.



The compound  $Fe_3O_4$  is called magnetite, and appears as a dark gray sludge within the system, as shown in figure 3. If oxygen continues to be present in the system, magnetite will be converted to hematite ( $Fe_2O_3$ ), which can cause pitting corrosion throughout the system.

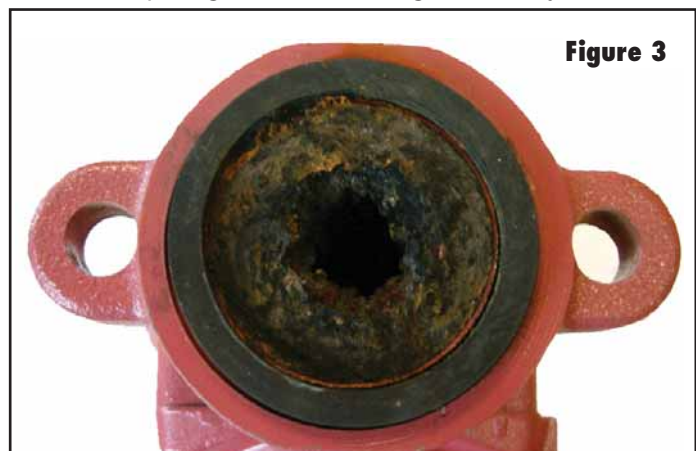

## Inadequate Flow:

Circulator impellers transfer maximum mechanical energy to incompressible fluids (e.g., liquids). A mixture of water and air is not an incompressible fluid. Although most circulators can move water with some entrained air, mechanical energy transfer is not as efficient as with fully deaerated water. This decreases flow and reduces the rate of heat conveyance by the system.

**Circulator Damage:** Modern wet-rotor circulators have ceramic bushings that depend on system water for lubrication. Due to its lower density, air tends to accumulate near the pump shaft in the vicinity of the bushings. The presence of air bubbles or air pockets can dislodge lubricating water and hence create premature bushing failure. The likely result is replacement of the entire circulator.

Circulators installed in vertical piping with upward flow and having spring-loaded check valves or flowchecks near their discharge are especially susceptible to large pockets of air (see figure 4). If a sufficient volume of air enters the volute and displaces water in the impeller, the circulator may be unable to clear itself and will quickly be running without lubrication. Failure is almost certain.

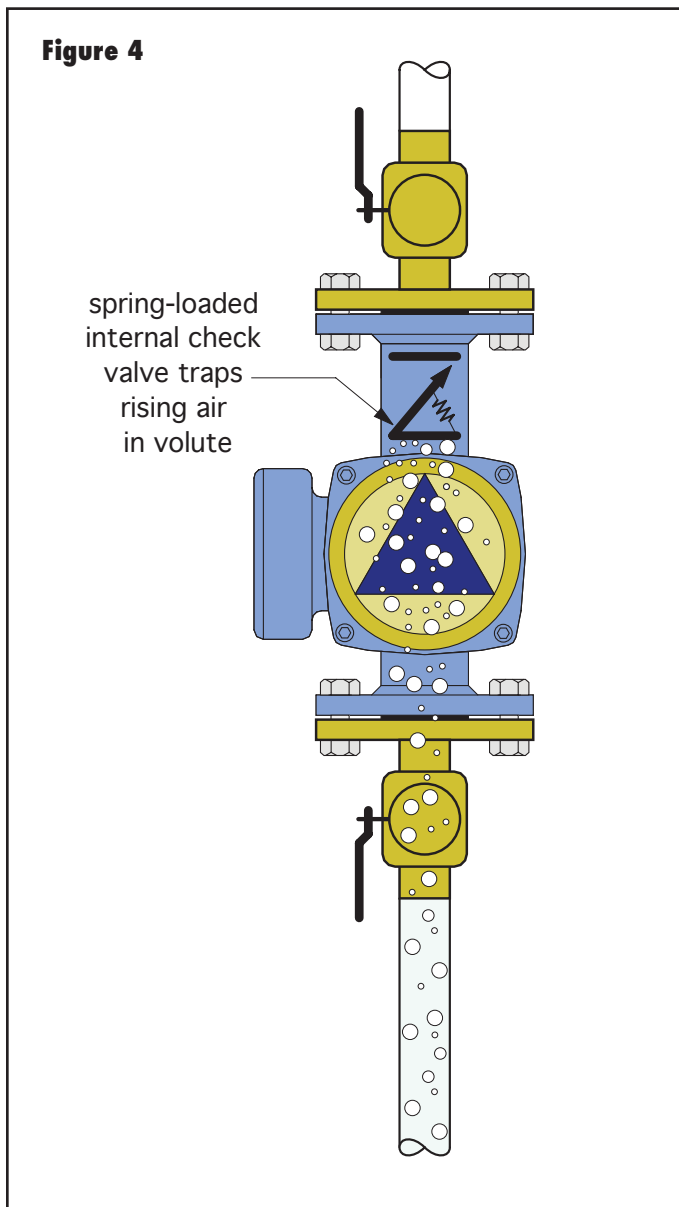

Gaseous cavitation occurs within circulators when the pressure at the eye of the impeller drops below the saturation pressure of gases such as oxygen or nitrogen in solution with the water. The dissolved gas molecules instantly form bubbles that interfere with circulator performance, as depicted in figure 5.

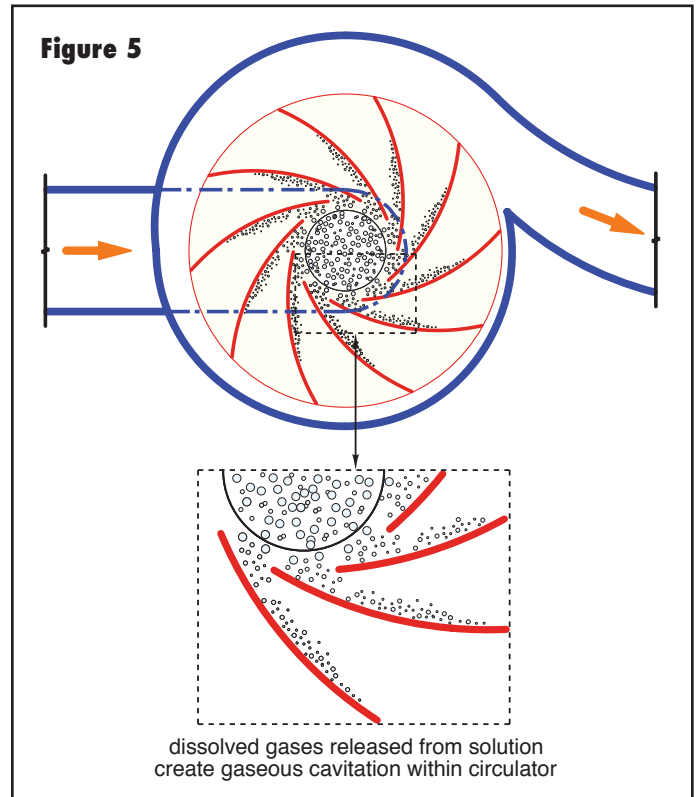

Sediments formed by oxidation within the system can be deposited on the impeller and volute of circulators, lowering their performance or causing total blockage (see figure 6).



**Improper Performance of Balancing Valves:** Hydronic balancing valves are precision devices designed to perform within tight specification when conveying liquids. The presence of air in the water changes the pressure drop vs. flow rate characteristics of the valves, allowing flow rates to drift away from desired settings. This in turn can lead to improper heat delivery in various portions of the system. Highly throttled balancing valves can also experience gaseous cavitation when water with a high dissolved air content passes through them.

**Complete Loss of Flow:** If a stationary air pocket is large enough, and the piping system is tall enough, the system's circulator cannot generate sufficient lift to force water over the top of the system (see figure 7). Under such circumstances there will be complete loss of flow in the circuit. Even if the circulator can establish some flow over the top of the system, that flow may not be sufficient to entrain air and help dislodge the air pocket.

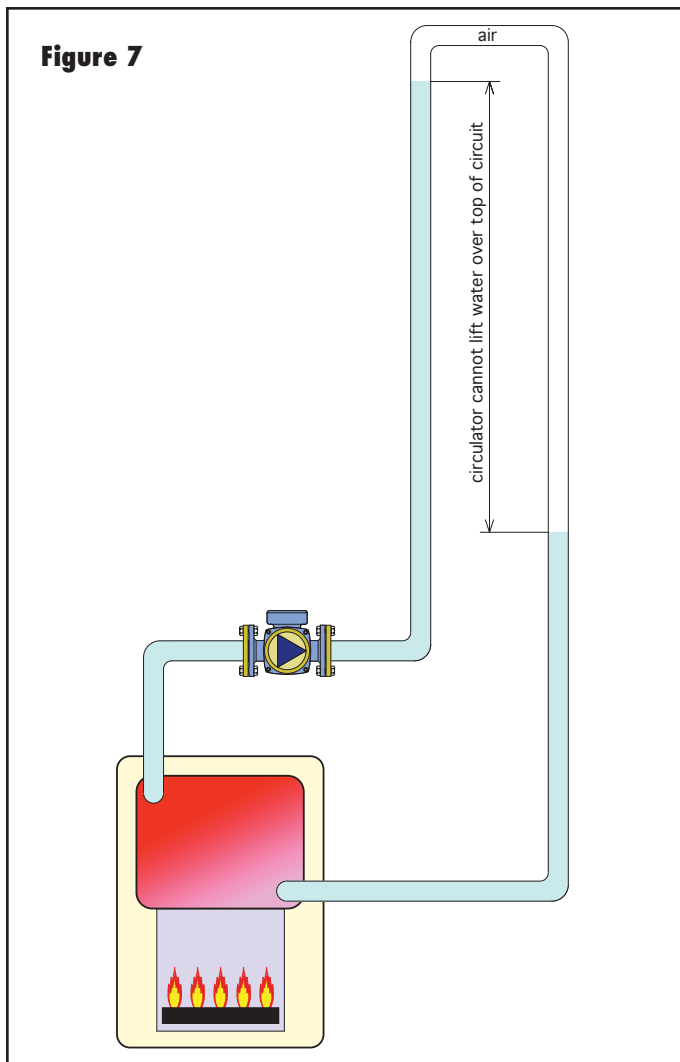

## FORMS OF ENTRAPPED AIR:

Air exists in three distinct forms within hydronic systems:

- Stationary air pockets at high points
- Entrained air bubbles
- Gases dissolved within water

Every hydronic system is completely filled with air prior to being commissioned. Stationary air pockets are typically the remnants of air not expelled when the system is first filled. In some systems, they may also exist due to an improper design or installation detail that allows air to reenter the system.

Since air is lighter than water, it migrates toward high points in the system. Such points are not necessarily at the top of the system piping. Stationary air pockets can form at the top of heat emitters, even those located at low elevations within a building. Air pockets can also form in horizontal piping that eventually turns downward, or piping that is routed above obstacles in its path, as shown in figure 8.

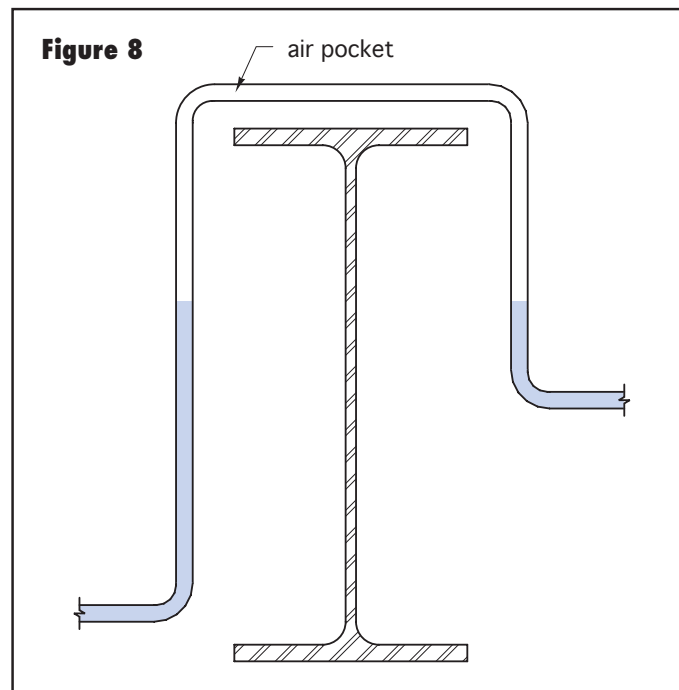

As water enters the system, these locations can trap air, especially if water approaches them from both directions. Slow water movement during the filling process also enhances air pocket formation.

Stationary air pockets can also reform as residual air bubbles merge together and migrate toward high points. This is especially likely in components with low flow velocities, where slow-moving fluid is unable to push or drag the air along. Examples of such components include large heat emitters, large diameter piping, and storage tanks.

### Entrained Air Bubbles:

A moving fluid *may* be able to carry air bubbles along (entrain them) through the system. This is desirable from the standpoint of conveying air bubbles from remote parts of the system back to a central air-separating device where they can be captured and expelled. However, if the fluid's flow velocity through the air-separating device is too high, the entrained air cannot be efficiently separated and could end up making many passes through the system.

The ability of a fluid to entrain air can be judged by its ability to move bubbles vertically downward, against their natural tendency to rise. If the fluid moves downward faster than a bubble can rise, it will pull the bubble along. *A minimum flow velocity of 2 feet per second is recommended to entrain air bubbles within downward-flowing pipes.*

An especially challenging form of entrained air in hydronic systems is referred to as microbubbles. Individually, microbubbles are too small to be seen by the human eye. However, dense collections of microbubbles can make otherwise clear water appear cloudy. A common place to see temporary clouds of microbubbles is in a drinking glass just filled with water from a faucet having an aerator device.

In hydronic systems, microbubbles form when water with dissolved gases such as oxygen and nitrogen is heated in a boiler. They can also form when water passes through a component that creates a sudden and significant pressure drop. An example of the latter is a throttling valve that is just slightly open.

Microbubbles have extremely low rise velocities and are easily entrained by moving fluids. This characteristic makes it more difficult to capture microbubbles. Later sections describe how this is done.

Unfortunately, some hydronic systems, especially older systems, have air-separating devices that do not provide sufficiently low flow velocities or internal details that allow efficient microbubble separation. While larger bubbles are captured due to their greater rise velocities, microbubbles are often swept through the air-separating device without being captured. The result can be a system that takes days, or even weeks, to reduce its air content to acceptable levels.

### Dissolved Air:

Molecules of the gases that make up air can exist "in solution" with water molecules. Since molecules are too small to be seen, water that appears perfectly clear and free of bubbles can still contain a significant amount of dissolved gases that ultimately need to be removed from the system.

The amount of dissolved gases that water can hold depends on the water's temperature and pressure. At higher temperatures, the ability of water to contain dissolved gases decreases and vice versa.

The contours in figure 9 show the *maximum* amount of dissolved air gases contained in water over a range of temperatures and pressures (expressed as a percentage of total volume). For example, at 30 psi absolute pressure (about 15.3 psi gauge pressure) and a temperature of 65°F, up to 3.6 percent of the molecules in a container of water can be dissolved gases (oxygen, nitrogen, and other trace gases). However, if the water's temperature is raised to 170°F while maintaining the same pressure, its ability to hold dissolved gas is reduced to 1.8 percent of its volume, half the previous level. Such a change in temperature would be typical of cold water heated within a boiler and illustrates the "degassing" effect of increased temperature.

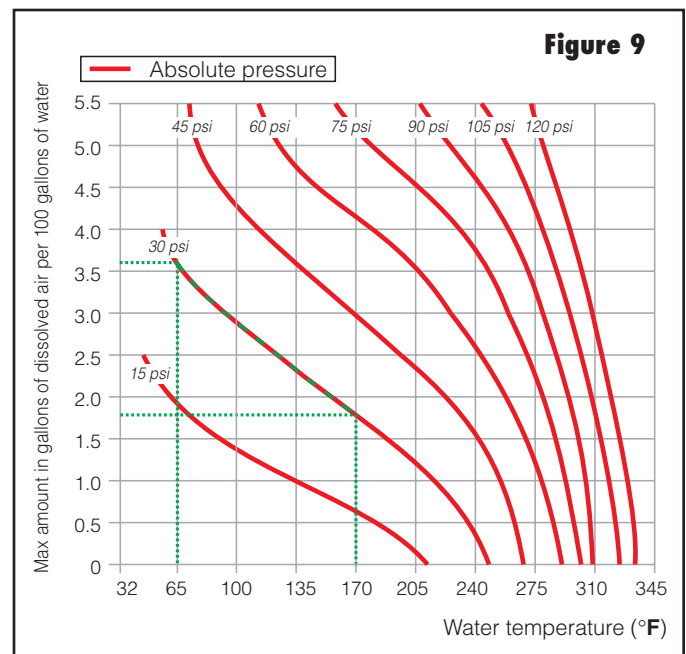

The pressure at which water is maintained also significantly affects its ability to contain dissolved air. At lower pressures, the ability of water to contain dissolved gases decreases and vice versa. Figure 9 shows that reducing the pressure of 170°F water from 30 to 15 psi absolute pressure (15.3 to about 0.3 psi gauge pressure) reduces the amount of dissolved gas it can contain from 1.8 percent to about 0.6 percent of its volume. This explains why air bubbles are more likely to form in the upper portions of a multi-story hydronic system. Lower static pressure in the upper portions of the building makes it easier for dissolved air to come out of solution. Higher static pressure near the bottom of the system tends to keep gases in solution.



**Figure 10**

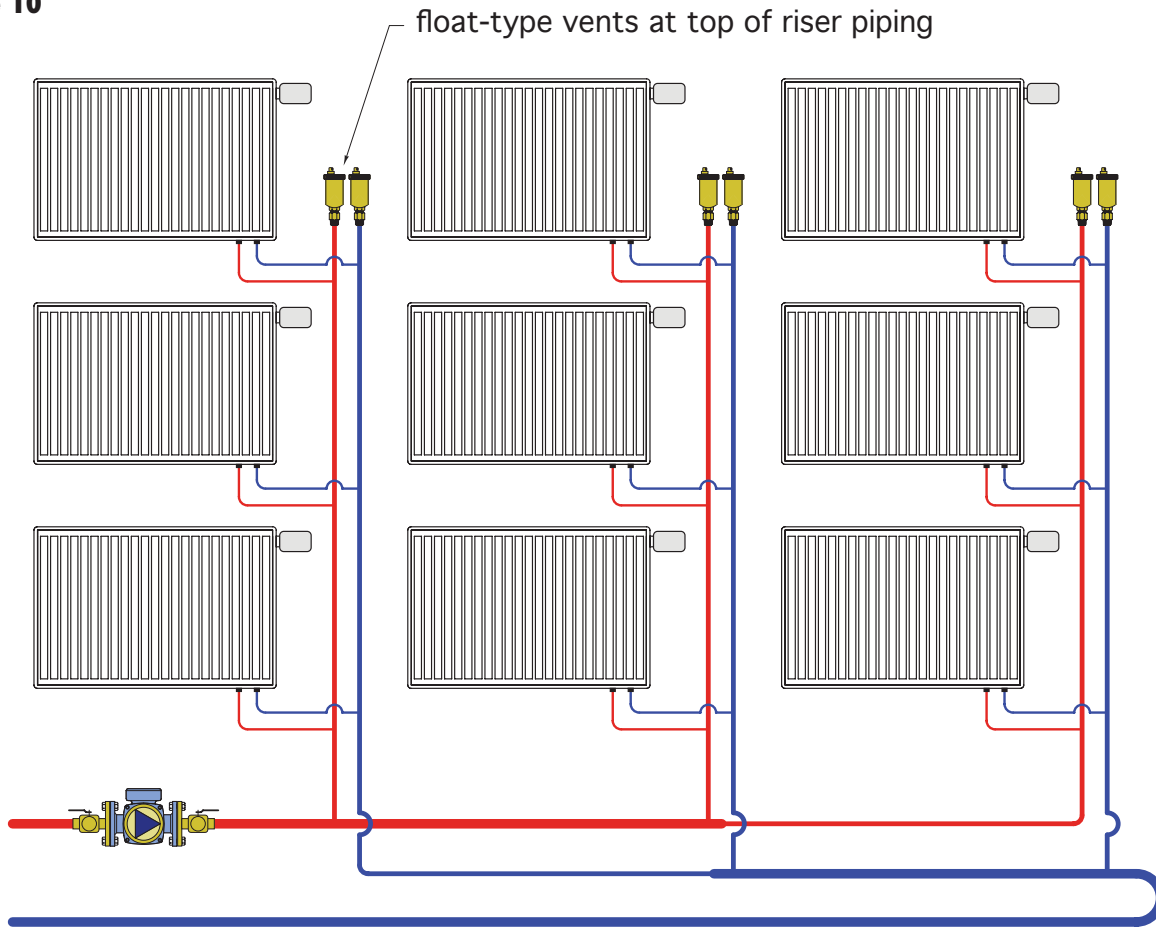

Water has the ability to repeatedly absorb and release gases as its temperature and/or pressure changes. This can affect hydronic systems in several ways — some good and some not so good. For example, the ability of water to absorb air as it cools helps reduce the volume of stationary pockets in areas of the system where flow is slow or non-existent. This absorbed air can be carried back to the boiler where it will be forced out of solution by heating. An efficient air-separating device can be “waiting” downstream of the heat source to capture the resulting microbubbles and eject them from the system. On the negative side, the ability of water to absorb air can also cause a condition called “water logging” in expansion tanks without diaphragms or bladders.

It’s always desirable to minimize the dissolved air content of the system’s water. This is accomplished by establishing conditions that encourage dissolved gases to come out of solution (e.g., high temperatures and low pressures). The sections that follow show how this is best accomplished in hydronic systems.

#### **AIR REMOVAL DEVICES:**

Most air removal devices used in hydronic systems can be classified as either high point vents or central air separators.

High point vents release air from one or more high points in the system where it tends to accumulate. Typical locations for such vents are the top of each heat emitter, the top of distribution risers (see figure 10), or wherever piping turns downward following an upward or horizontal run. High point vents are particularly useful for ejecting air during or immediately after the system has been filled with fluid (e.g., at startup or after servicing).

A central air separator is used to remove entrained air from a flowing fluid, as well as to maintain the system at the lowest possible air content.



### Manual Air Vents:

The simplest type of high point venting device is a manual air vent. These components are essentially small valves that thread into 1/8-inch to 1/2-inch FPT tapings, and are operated with a screwdriver or square head key. When opened, air moves up through the valve seat and exits through a small side opening.

Manual air vents are commonly installed at the top of each heat emitter. An example of a manual air vent installed at the top of a towel warmer radiator is shown in figure 11. Such vents are opened to release air that rises to the high point as fluid enters lower in the system. When the fluid level reaches the manual air vent, a small stream of water will flow out the side of the vent. A small piece of flexible tubing can be used to guide this stream into a can or pail. It's important to capture this water and not allow it to stain carpets or otherwise damage surrounding materials. When a steady stream of water has been flowing from the vent for several seconds, it should be closed.



**Figure 11**

### Hygroscopic Air Vents:

Another type of small high point venting device is called a hygroscopic air vent. An example of such a device is shown in figure 12. These devices contain a special cellulose fiber disc that, when dry, allows air to pass through it and exit the vent. When water reaches the disc, it expands within a few seconds to stop further flow from the device.



**Figure 12**

Hygroscopic air vents can be used in either automatic or manual mode. When the knob is set one turn open, they operate identical to a manual air vent. When the knob is closed, they allow air to pass but reseal as soon as water contacts the internal fiber disc.

Minerals or sediment in the system water can interfere with the operation of the internal hygroscopic disc. It is generally recommended

that these discs be replaced every three years. Although hygroscopic air vents are automatic, they can be manually opened and are therefore not recommended in locations where tampering is possible. A float-type air vent is a preferred choice in such locations.

### Float-type Air Vents:

A float-type air vent provides fully automatic air release and instantaneous response to the presence of water. An example of such a device is shown in figure 13.

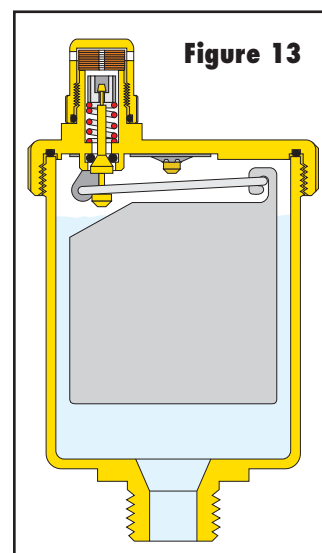

**Figure 13**

It contains an air chamber, a float assembly and an air valve (see figure 13). As air accumulates within the chamber, the float descends. A linkage attached to the float eventually opens the valve mechanism at the top of the unit. As air is released, water flows into the chamber and lifts the float to close the valve. Some Caleffi float-type vents are equipped with hygroscopic caps that seal the vent from water leakage in the event that the internal valve mechanism did not operate properly.

**Figure 14**

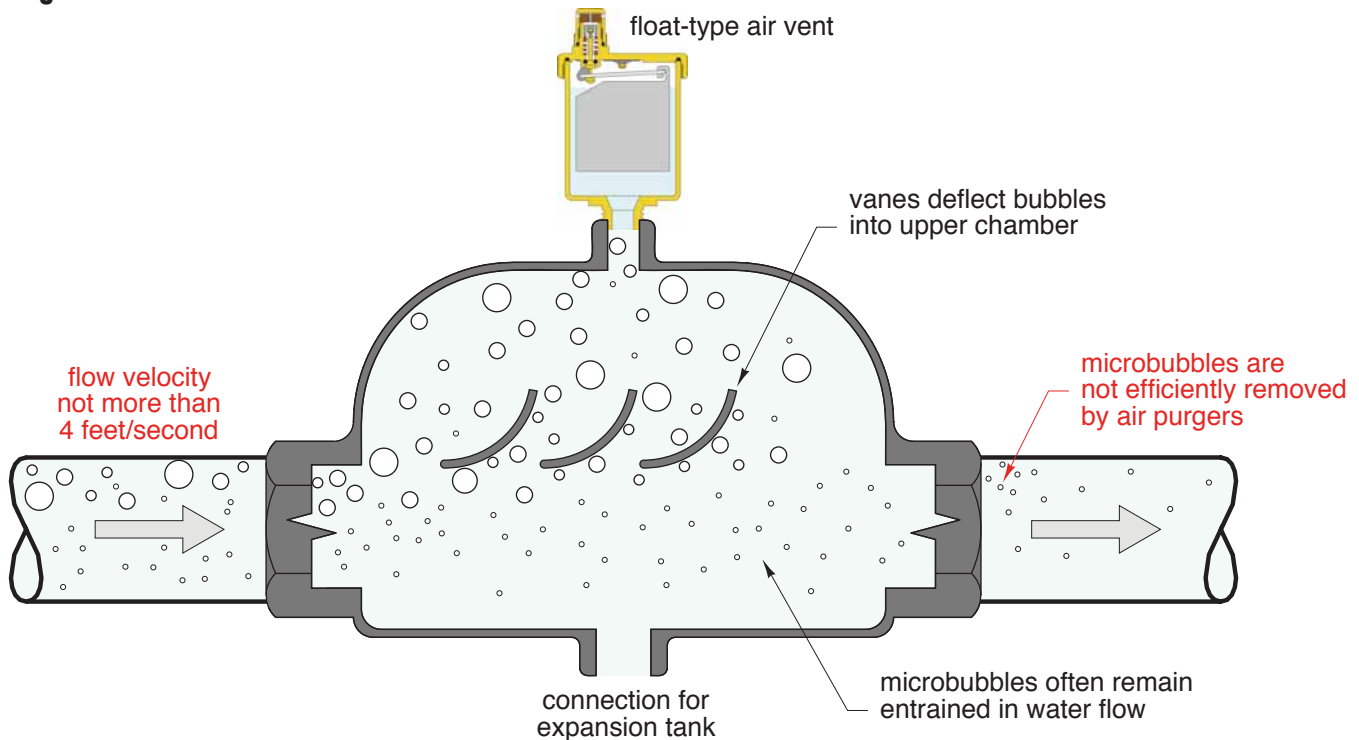

Most float-type air vents are equipped with a cap that protects the valve mechanism from debris. It's important that this cap is loosened when the vent is put into service. If the cap is fully closed, the vent cannot operate.

Float-type air vents are available in different sizes and shapes that allow mounting of both horizontal and vertical orientations. Compact designs allow mounting within the enclosures of heat emitters, such as fin-tube convectors or fan-coils. Larger "high-capacity" vents are available for use atop central air separators or other locations where high-volume air venting is needed.

It's important to remember that float-type air vents can also allow air to *enter* the system if the system pressure at their installed location drops below atmospheric pressure. This can happen as a result of improper placement of the expansion tank relative to the circulator. It can also be caused by low static pressure in the system. It's good practice to design and commission all closed-loop hydronic systems so there is at least 5 psi of positive static pressure at the top of the system. This ensures that float-type vents will always be able to expel any air that accumulates. Caleffi vents can be equipped with "anti-siphon" caps that prevent airflow *into* the vent if the pressure at the vent location drops below atmospheric pressure.

#### **Central Air Separators:**

The ability to maintain very low air levels within a closed-loop hydronic system is vital to quiet, efficient and reliable operation. The key component in providing this function is a central air separator. Such devices can be categorized as either air purgers or microbubble air separators.

Air purgers are relatively simple devices that encourage well-formed air bubbles to rise into a collection chamber and pass out through a float-type air vent at the top of that chamber. They rely heavily on the buoyancy of well-formed bubbles as the means of separation. *To achieve proper operation, the velocity of the flow stream entering the separator must be kept below 4 feet per second.* Lower velocities increase the air removal efficiency of these devices, albeit at the cost of larger and more expensive hardware. Air purgers are not designed to capture microbubbles, and as such, cannot lower the dissolved air content of the system as well as separators specifically designed for this purpose. A cutaway illustration of a typical air purger is shown in figure 14.

### Microbubble Air Separators:

Previous sections discussed gases dissolved in water as well as the characteristics of microbubbles. These forms of air are more difficult to capture relative to well-formed bubbles or large air pockets. Doing so requires surfaces upon which microbubbles can cling and eventually merge into larger bubbles. This process is called coalescence, and it's vitally important to attaining and maintaining minimum air levels in hydronic systems.

As microbubbles coalesce together, they form larger bubbles. Eventually the bubbles attain a volume large enough that buoyancy forces overcome the adhesion forces holding them to the coalescing surface. The bubbles then rise along the coalescing surfaces to a chamber above the main flow stream where they can be collected and expelled through a float-type air vent. The concept of coalescence inside such a separator is illustrated in figure 15.



Figure 15

The surface on which microbubbles coalesce is called the “coalescing media.” Some microbubble air separators use metal meshes for this media, while others use special polymers. In either case, the coalescing media must provide high surface contact area, enhancement of vertical bubble movement and a relatively low pressure drop. Figure 16 shows the coalescing media cartridges used in Caleffi Discal microbubble air separators.

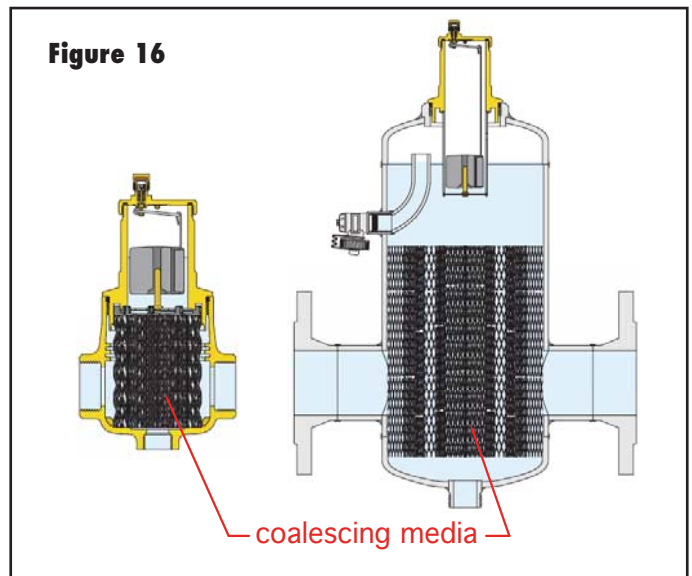

Figure 16

### PLACEMENT OF CENTRAL AIR SEPARATORS:

Central air separators work best when located where the solubility of dissolved gases within the system water is lowest. In heating systems, they should be mounted near the *outlet* of the heat source (see figure 17). In cooling systems, they should be mounted on the *inlet* side of the chiller (e.g., where water temperatures are highest).

Notice how the air separator placement in figure 17 allows flow through it during space heating as well as domestic water heating operating modes. The greater the number of times system water passes through the heat source and central air separator, the better the latter device can “scrub” dissolved gases from the water and expel them.

The ability of a microbubble air separator to lower the water's dissolved gas content allows that water to absorb air back into solution as it cools. A common example of this is water cooling within piping and heat emitters during an off-cycle. Think of this cooling water as a “sponge” that soaks up molecules of air gases with which it comes in contact. Since these molecules are pulled into and held in solution under these conditions, they will eventually be carried back to the heat source when flow resumes. Upon heating, they will be released from solution as microbubbles and captured by the microbubble air separator. This process is ongoing and can eventually bring the dissolved air content of the water to approximately 0.4 percent of system volume. In this state, the water can provide efficient and virtually silent conveyance of heat, and its very low oxygen content discourages corrosion.

**Figure 17**

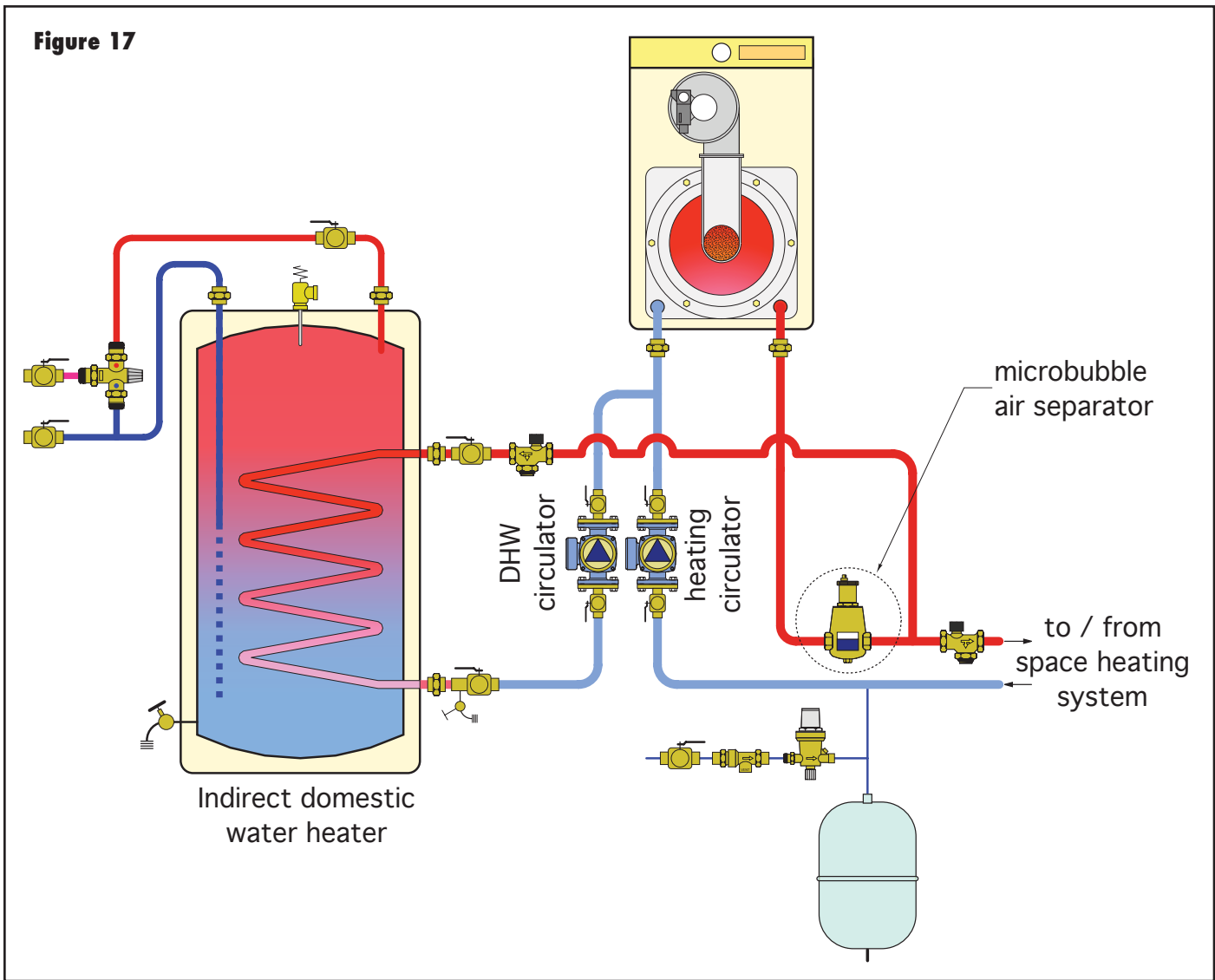

**DIRT SEPARATION:**

There are many ways dirt can enter a hydronic system. Perhaps the most common is through repeated handling of piping and system components from manufacturing through transportation and eventually during installation. Piping and components stored on-site can accumulate wind-blown dust or even larger dirt particles if dragged over the ground or dirty floor surfaces. Insects can nest in piping stored in warehouses or on jobsites.

Sediments can also be present in hydronic systems, especially older systems containing steel or iron piping and cast iron radiators. This is especially true for systems that originally operated with steam and are being converted to hot water circulation. Even new cast iron boilers or radiators can contain residue associated with their manufacturing. Metal chips

from reaming copper or iron piping often lodge inside pipes during installation. Excess solder often forms small pellets inside piping. Welding slag grains are also common in systems using steel pipe.

**DIRT-RELATED PROBLEMS:**

It goes without saying that the ideal hydronic heating or cooling system would be dirt-free. The presence of dirt can have serious consequences, including:

- Damage to rotating components in circulators, especially impeller and bushing surfaces. An example of a circulator with a completely clogged impeller due to sediments in a system is shown in figure 18.
- Reduced heat transfer due to “fouled” surfaces in heat emitters, heat exchangers, and heat sources, especially those using compact heat exchangers.





**Figure 18**



**Figure 19**



**Figure 20**

- Similar fouling damage to heat transfer surfaces within chillers.
- Erosion of internal piping surfaces, especially copper tubing (see figure 19).
- Discoloration of transparent wetted surfaces, such as those on sightglasses or flow meters, as shown in figure 20.
- Erosion and/or clogging of relief valves, balancing valves, check valves, venting valves, and thermostatic radiator valves, as depicted in figure 21.

neck of a funnel. All system flow passes through the strainer and particles larger than the mesh size of the basket are trapped. Particles smaller than the mesh size may pass through. On most Y-strainers, the basket must be periodically removed to clear it of debris.

**DIRT SEPARATION METHODS:**

There are three common methods for capturing and expelling dirt from hydronic systems:

1. Use of chemical “floculants” to wash the inside of the system.
2. Use of basket strainers.
3. Use of low-velocity-zone particle separators.

Chemical flocculants act as detergents within piping systems. They provide the chemical reactions necessary to dislodge certain types of accumulated sediments and assist in bonding fine particles together so they can be entrained in a flowing stream. A typical system cleaning procedure involves adding the flocculants to the system, then operating it at elevated temperatures for several hours so that accumulated sediments or corrosion residuals can be dislodged and carried along by the flow. The system is then drained and flushed with clean water to expel as much of the sediment as possible. This procedure can be done when the system is first commissioned or as a remedial measure for systems in which sediments or corrosion scale have decreased performance. Some flocculants also coat the inside of piping and components with a residual film to protect against corrosion.

Basket strainers, also known as Y-strainers, entrap dirt within a “basket” made of stainless steel or brass mesh. In essence, they work the same as a strainer inside the

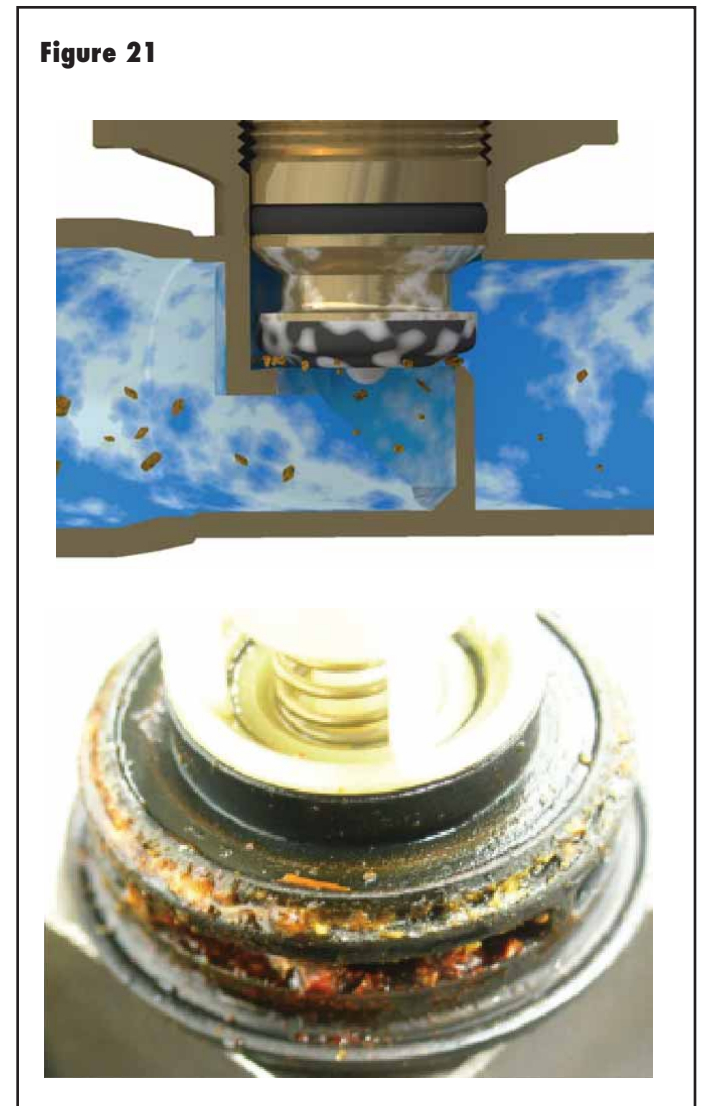

**Figure 21**

As debris collects in a basket strainer, it impedes flow. This results in increased pressure drop and hence higher head loss. If the strainer basket is not properly maintained, such head loss can be excessive. Flow reductions due to such head loss also reduce heat conveyance by the system. When restricted strainers are present near the inlet of circulators, they can induce vapor cavitation due to significant pressure drop. This can severely damage a circulator if not corrected.

In some systems, the pressure drop across a basket strainer is monitored to determine when cleaning is necessary. Ball valves are installed to isolate the strainer so its basket can be removed without significant fluid loss, as shown in figure 22. Flow through the system obviously needs to be stopped during this procedure.

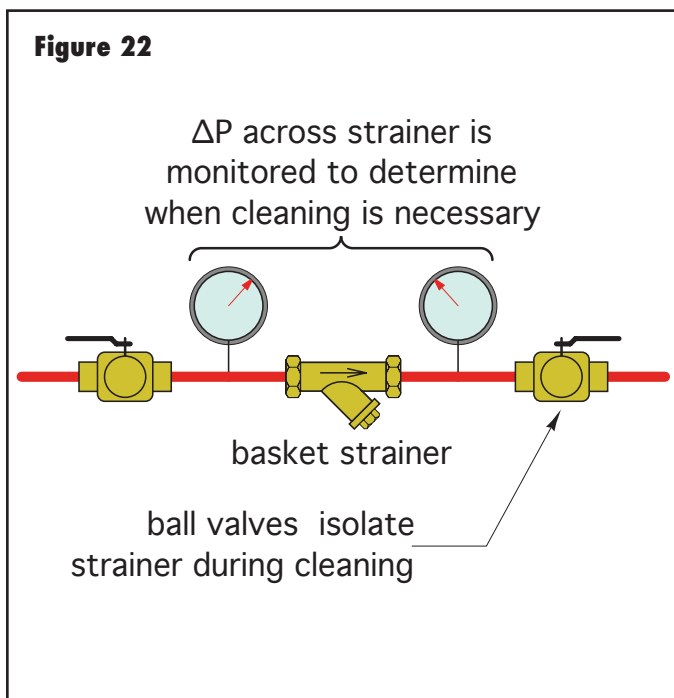

Low-velocity-zone dirt separators use a principle similar to that already discussed for separation of microbubbles. Water flows into the device along with entrained dirt particles. Its flow velocity is greatly reduced by the wider cross-section of the separating chamber. The entering dirt particles tend to move downward due to their density. A specially designed media within the device provides surfaces that assist in separating the dirt particles and guiding them downward into a low velocity chamber where they continue to settle to the bottom of the separator. When a valve at the bottom of the chamber is opened, the accumulated dirt is “blown down” (e.g., expelled) to a hose or bucket. An example of a Caleffi Dirtcal low-velocity-zone dirt separator is shown in figure 23.

A typical low-velocity-zone dirt separator only creates about 25 percent of the pressure drop of a comparable size basket strainer. It can also remain in service for relatively long periods between blowdowns due to its ability to collect or hold sediment away from the flow stream. Flow through the system does not need to stop during the blowdown procedure.

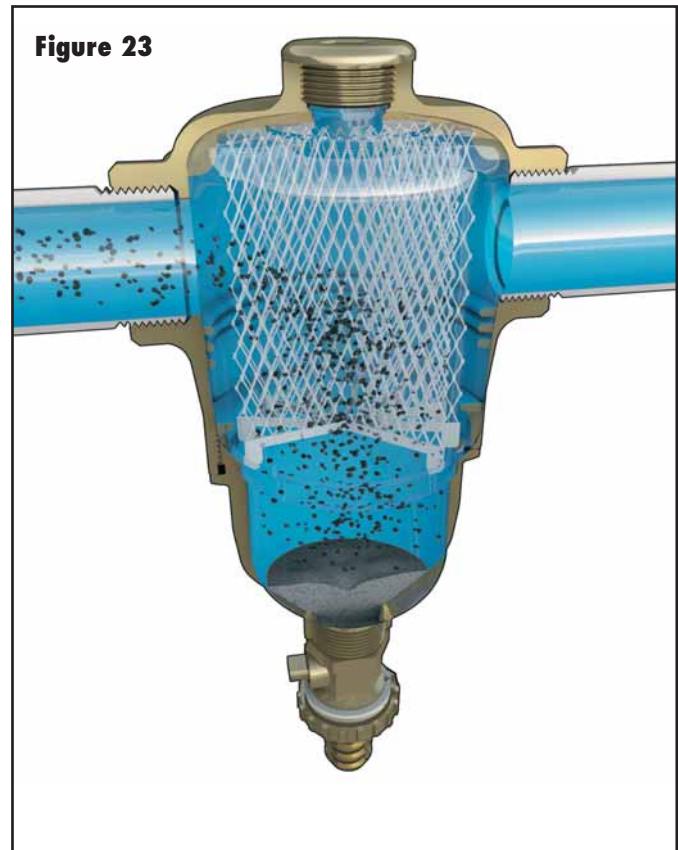

As with air separation, flow velocity through a low-velocity-zone dirt separator affects performance. The maximum *preferred* flow velocity through such a device is 4 feet per second. Lower flow velocities reduce the time required to separate the dirt and yield slightly lower head loss. Operation at flow velocities up to 10 feet per second is possible, but higher flow velocities reduce separation efficiency.

**EFFICIENCY OF DIRT SEPARATION:**

No dirt separator can capture 100 percent of the dirt in a stream of water during a single pass through the device. This is especially true of very small particles, which are easily entrained with flow. The smaller the particles, the greater the number of cycles needed to remove them. Figure 24 shows the results of a particle separation test performed on a Caleffi low-velocity-zone dirt separator. Results reflect particle size, flow velocity, and the number of passes (e.g., number of times the entire system volume has passed through the separator).

Testing has shown that Caleffi low-velocity-zone separators can remove nearly 100 percent of small sand particles in sizes greater than 100 micrometers (approximately 0.004 inches) when operating with flow rates up to 4 feet/second. Eventually these separators can remove particles as small as 5 micrometers (approximately 0.0002 inch). This dimension is less than 1/10<sup>th</sup> the diameter of a human hair, and much smaller than the particle size that can be captured by a typical Y-strainer.

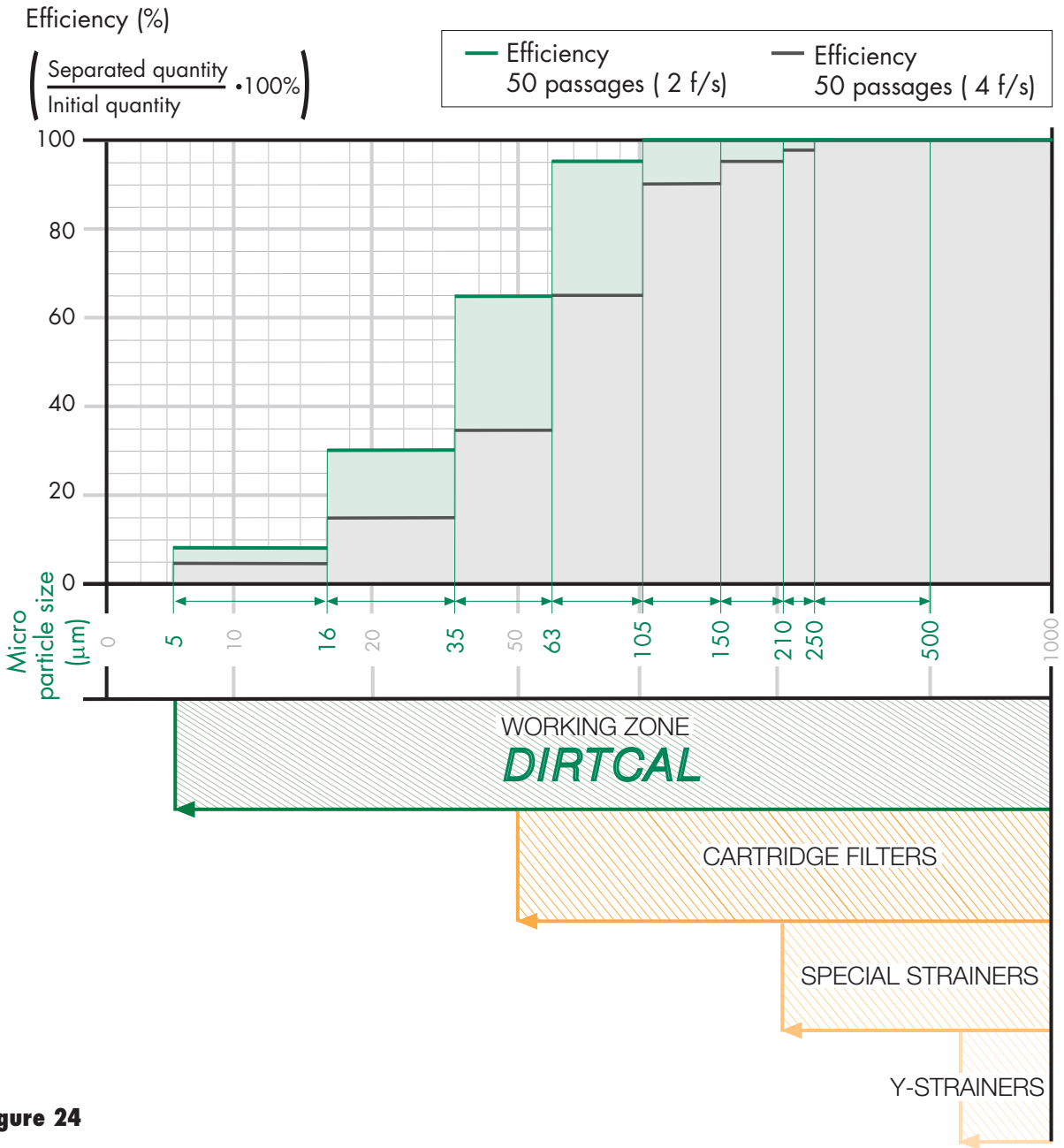

**Figure 24**

### PLACEMENT OF DIRT SEPARATORS:

Because most dirt particles have a density greater than water, they tend to migrate toward the lower portions of the system. Thus it makes sense to separate and capture them in this area. *It also makes sense to continually route system flow through a dirt separator to increase the number of passes the system volume makes through the device in a given amount of time.*

Dirt separators are commonly placed on the inlet side of boilers and other heat sources, as shown in figure 25. This is especially important in systems using boilers or other heat sources with compact heat exchangers. It's also very important in systems where a new boiler is installed in a system containing older piping and/or cast iron radiators. Figure 26 shows such a situation. The dirt separator is placed on the return side of the distribution system to capture particles that might otherwise flow through the new boiler.

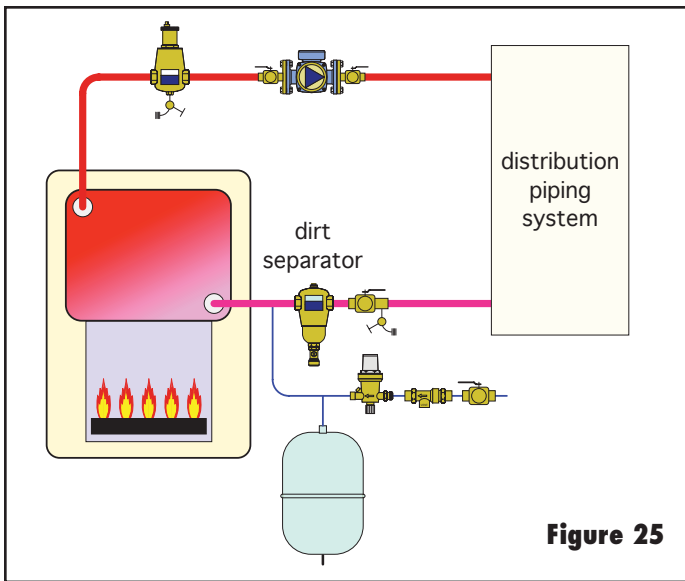

Figure 25

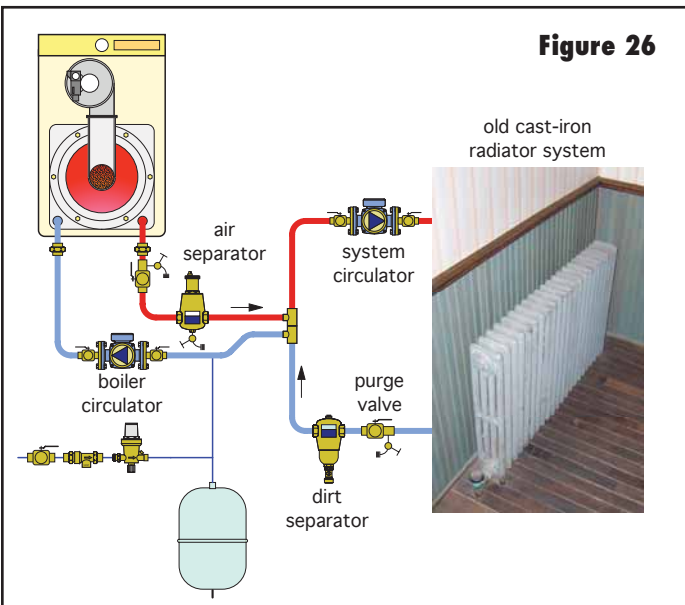

Figure 26

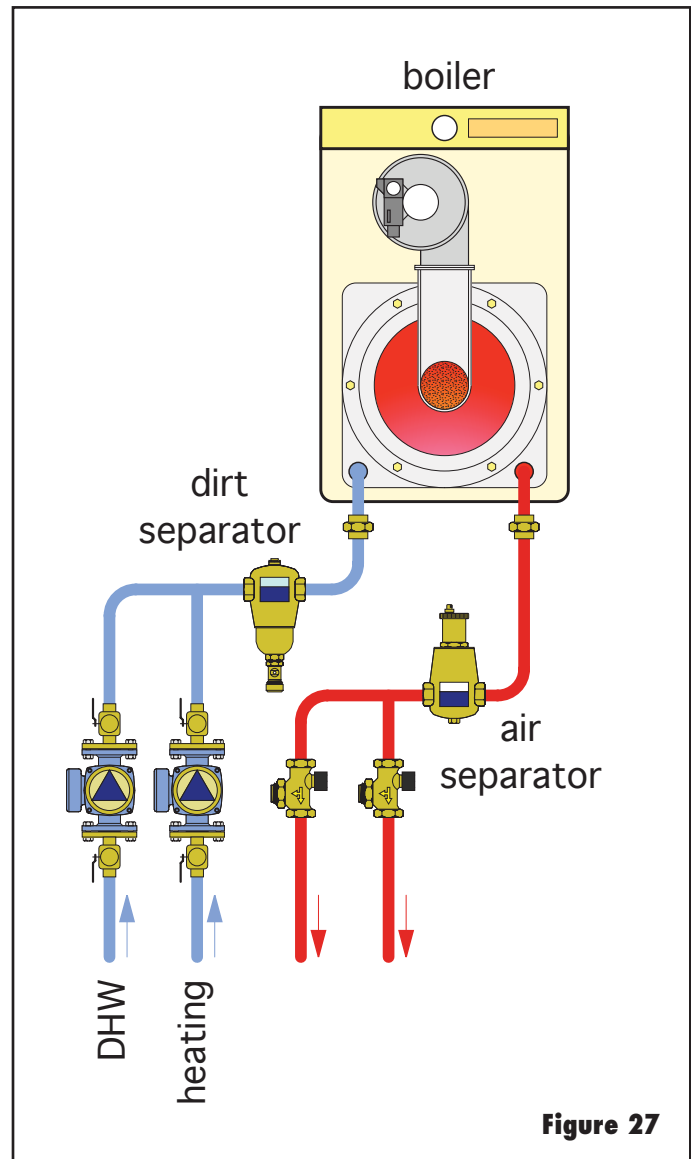

Figure 27

Notice that purging valves have been located just upstream of the dirt separator. This allows some of the dirt in the system to be flushed out during initial filling and purging (discussed later in the article). This in turn decreases the amount of dirt the separator will eventually have to capture.

When possible, it's also desirable to place the dirt separator upstream of circulators. This helps extract dirt prior to flow passing through the circulator. When doing so, allow at least 12 pipe diameters of straight pipe between the outlet of the air separator and inlet of the circulator.

Some systems use multiple circulators to push flow from different circuits into the boiler. In this case, the compromise is to place the dirt separator upstream of the boiler, as shown in figure 27.



In systems with a main mixing valve, it's best to place dirt separators in the return line from the distribution system ahead of the valve. This increases flow through the separator and also better protects the mixing valve from dirt (see figure 28).

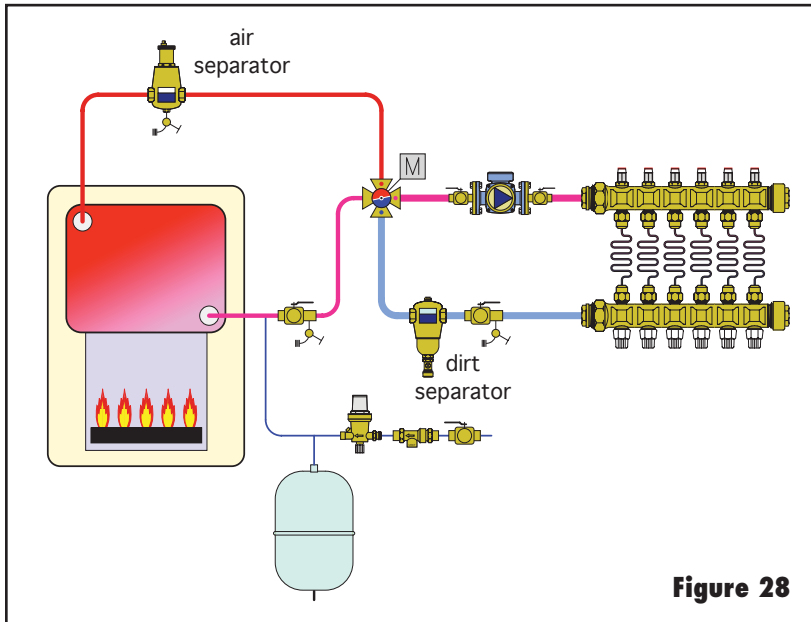

**Figure 28**

**COMBINED AIR & DIRT SEPARATORS:**

Some designers prefer to combine the function of air separation and dirt separation into a single device. This approach saves space, especially in tight mechanical rooms. It also reduces cost relative to installing two individual separators.

The preferred placement of a combination air & dirt separator depends on system piping. In systems where all system flow passes through the boiler, the best location is on the outlet of the boiler where microbubbles are likely to occur. In systems using mixing valves, the preferred location is on the mixing valve outlet where the water temperature is still elevated (and thus microbubbles are likely), and where system water flow rate is highest (and thus the fluid makes more passes through the device in a given amount of time). The latter consideration improves dirt separation efficiency. Both situations are shown in figure 30.

With all installations, be sure to plan sufficient space to connect a drain hose or place a bucket under the dirt separator to capture the expelled fluid and dirt.

Low-velocity-zone dirt separators are also well-suited to protect the small fluid passageways within plate-type heat exchangers from dirt accumulation. Separators should be installed near the inlets of both the primary and secondary sides of the heat exchanger, as shown in figure 29.

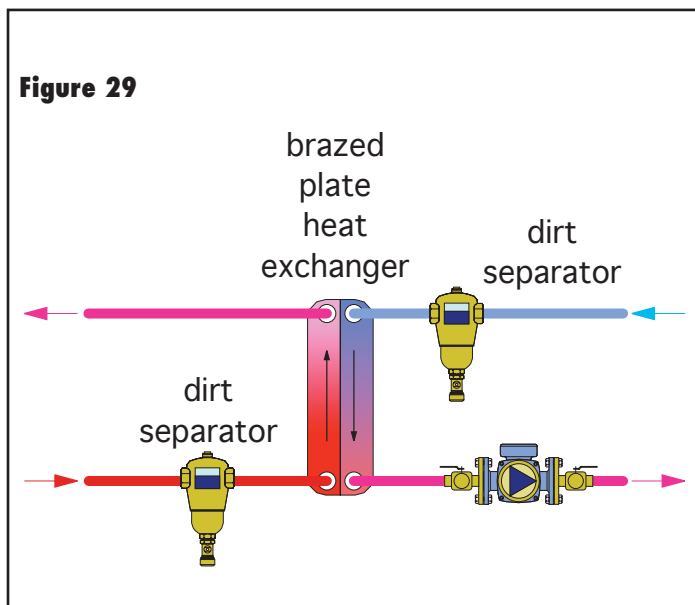

**Figure 29**

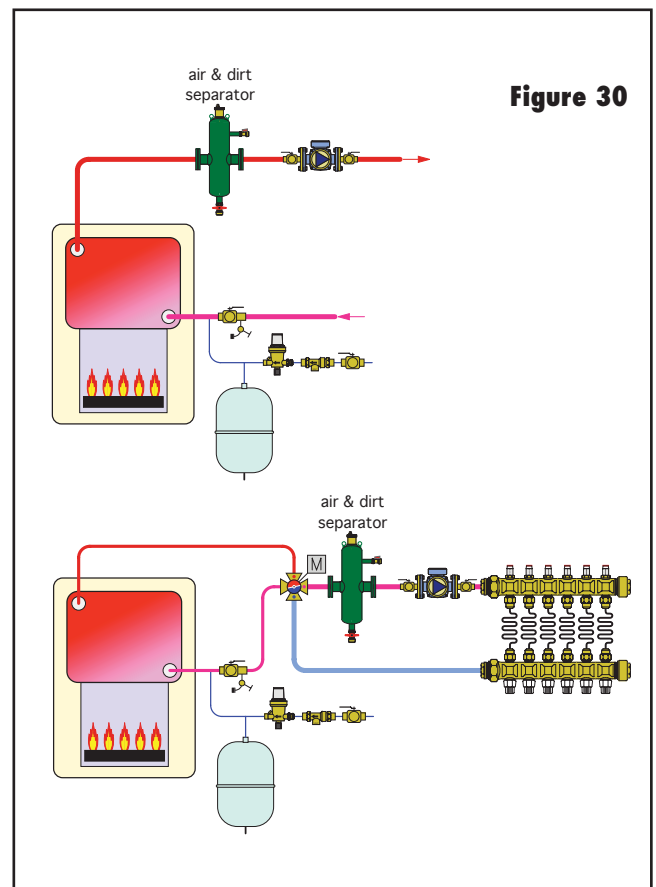

**Figure 30**

## FILLING & PURGING HYDRONIC SYSTEMS:

This section discusses basic concepts and procedures for adding water to a system and purging it of air. These techniques rely on the principles and air-elimination hardware previously discussed.

### Automatic Make-up Water Assemblies:

Most hydronic systems experience very minor water loss over their life due to weepage at valve stem packings, circulator flange gaskets, or “microleaks” from threaded fittings. If this water is not replaced, system pressure eventually drops and operational problems develop. The most common remedy for water-based hydronic systems is to equip the system with an automatic make-up water assembly. This usually consists of a backflow preventer, automatic feed valve, isolating valves, and possibly a strainer and pressure gauge. A typical automatic make-up water assembly is shown in figure 31.

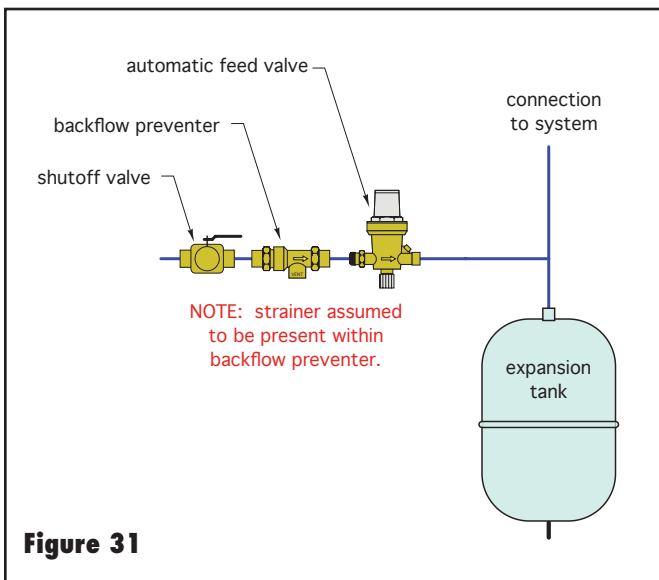

**Figure 31**

Although individual components can be joined together with fittings to create this assembly, several manufacturers offer pre-built assemblies to save time and reduce space requirements.

In most residential systems, the automatic make-up water assembly uses 1/2-inch pipe size components. Large commercial systems often use 3/4-inch size components for higher water flow rates during the filling/purging process. A full-port ball valve can be piped in parallel with an automatic feed valve to provide higher filling rates in large commercial systems. This concept is shown in figure 32.

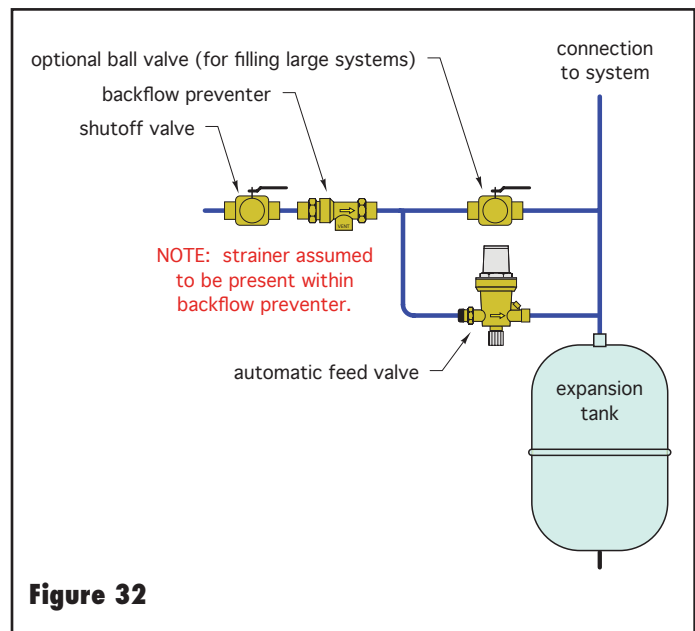

**Figure 32**

The high flow bypass valve is installed in the straightest piping path leading to the system connection. This minimizes pressure loss and provides the highest flow rate possible for filling and purging. Once the system is filled and purged, the high flow bypass is turned off. Its handle should then be removed to prevent accidental operation, especially by those who don't understand its function. The automatic feed valve remains active to provide all necessary water inlet to make-up for minor water losses.

Some installers prefer to turn off the shutoff valve on the automatic make-up water assembly once the system is filled and purged. This prevents sustained water flow into the system should it ever develop a leak. However, if this is done, it's important that someone periodically monitors system pressure and temporarily opens this valve when necessary to allow the automatic make-up assembly to restore normal system pressure.

### Purging:

The process of forcing air out of a hydronic system as water enters that system is called purging. Every hydronic system must be purged when it's commissioned. In some cases air rises upward within the piping as water is introduced lower in the system. In other cases air is forced along the piping by a rapidly moving water stream, and eventually exits through an opened valve. Both forms of purging are discussed in the following sections.

### Rising Water Purging:

Some of the air inside an empty hydronic system can be expelled as water enters through the automatic make-up water assembly. The concept is to introduce water low within the system, allowing it to displace air in the upward direction. High point venting devices such as those previously discussed allow rising air to leave the system. The pressure supplied by the water source must be sufficient to lift the water to the top of the system. *Circulators within the system are not used to fill the system with water.*

Air pockets often take several minutes to vent through low capacity vents. This method of purging, although simple in concept, is slow in execution, especially if high point vents are not properly located. It's fair to say that very few modern hydronic systems can be completely filled and purged using this procedure alone.

### Flow-through Purging:

The amount of air that can be rapidly expelled from a system during filling is significantly increased when the entering fluid has sufficient velocity to entrain air bubbles and carry them to an outlet valve. The greater the water pressure and flow volume available, the faster flow-through purging can push air out of the system.

One method of flow-through purging is to add a boiler drain valve and full-port ball valve (or a combination purging valve) to the piping leading into the boiler, as shown in figure 33.

Locating the circuit-purging valve near the *inlet* connection of the boiler and *upstream of the dirt separator* helps flush debris out of the system, rather than into the boiler. It also reduces the amount of dirt that eventually collects within the dirt separator.

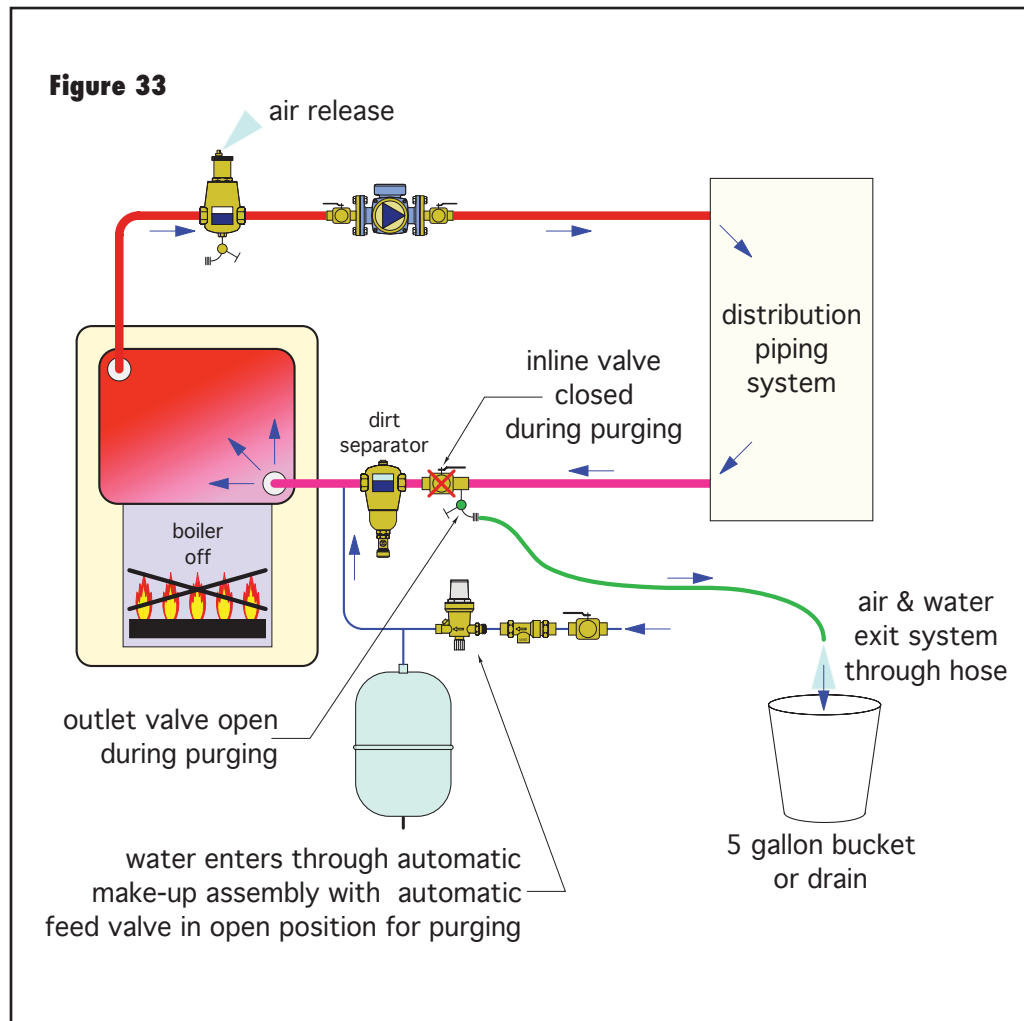

Flow-through purging begins by opening the outlet valve that connects to a drain hose. The automatic feed valve is then manually opened to allow rapid water flow into the system. If a high flow bypass valve is provided in parallel with the automatic feed valve, it should also be opened to maximize the rate of water entry to the system.

Because the ball valve on the boiler inlet pipe is closed, the entering water begins filling the boiler. Air within the boiler is displaced as the water enters. In some systems, this air exits through a vent at the top of the boiler; in others, it migrates up to the central air separator and exits.

When the boiler is full, water flows out to the distribution system, displacing air ahead of it. This air is pushed along by the rapid water flow and exits through the open hose bib or side port of a combination purging valve near the boiler inlet. A hose leads this water to a collection pail or directly to a floor drain.

Purging continues until the discharge stream is free of visible air bubbles for at least 30 seconds. At this point, most of the bulk air will have been purged from the system. The high flow bypass valve and purging outlet valve are closed and the fast fill function of the automatic feed valve is turned off. Caleffi Autofill valves do the latter function automatically.

In systems with two or more branch circuits, the preferred approach is to purge through one branch at a time. When the flow exiting the purge valve is free of air bubbles, the purging valve on the next branch circuit

is opened and the previous one is closed. This allows the maximum possible flow rate through each branch circuit, one at a time, to dislodge and entrain as much air as possible. This technique is especially helpful on radiant panel systems or homerun distribution systems having several parallel circuits. Manifold valves can be used to open and close each circuit as needed. After all branches have been purged individually, open them all up at the same time and continue flow-through purging. The lowered resistance of the fully open distribution system maximizes flow rate and helps dislodge any remaining air pockets in larger piping and components. If the system has a differential pressure bypass valve, it should be temporarily closed during purging. The concept and hardware placement for filling and purging systems with parallel branches is shown in figure 34.

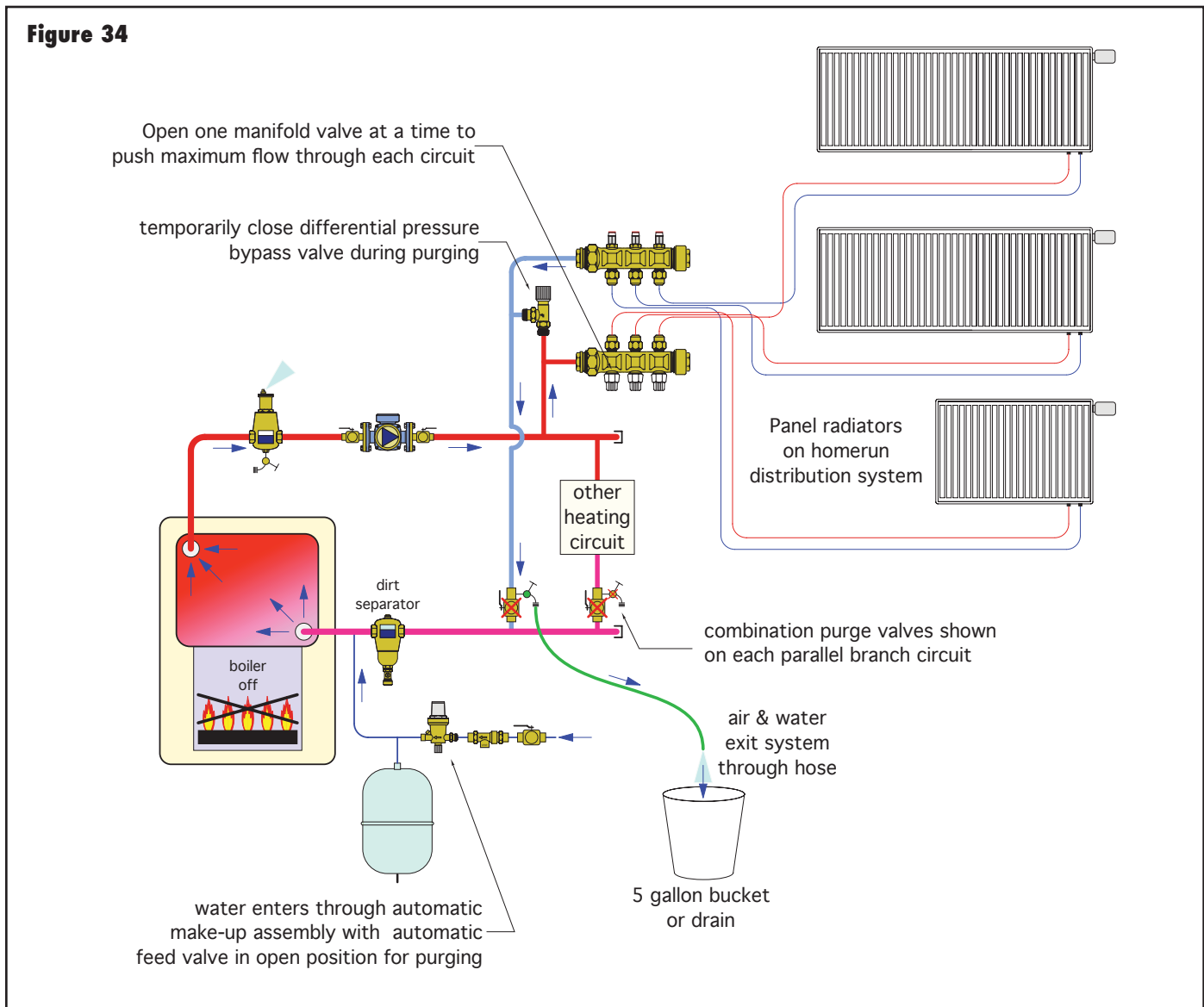



In a primary/secondary distribution system, it's important to include purging valves on each secondary circuit as well as the primary loop. When purging these systems, the preferred approach is to first isolate all secondary circuits, then purge the primary loop using the procedure described above. Once the primary loop is purged, proceed by purging each secondary circuit

one at a time. This requires a separate purging valve for each secondary circuit, as shown in figure 35.

On systems using zone circulators or zone valves, it's common to install a combination purging valve on the return side of each zone circuit, as shown in figure 36. This arrangement allows each circuit to be separately filled and purged during commissioning.

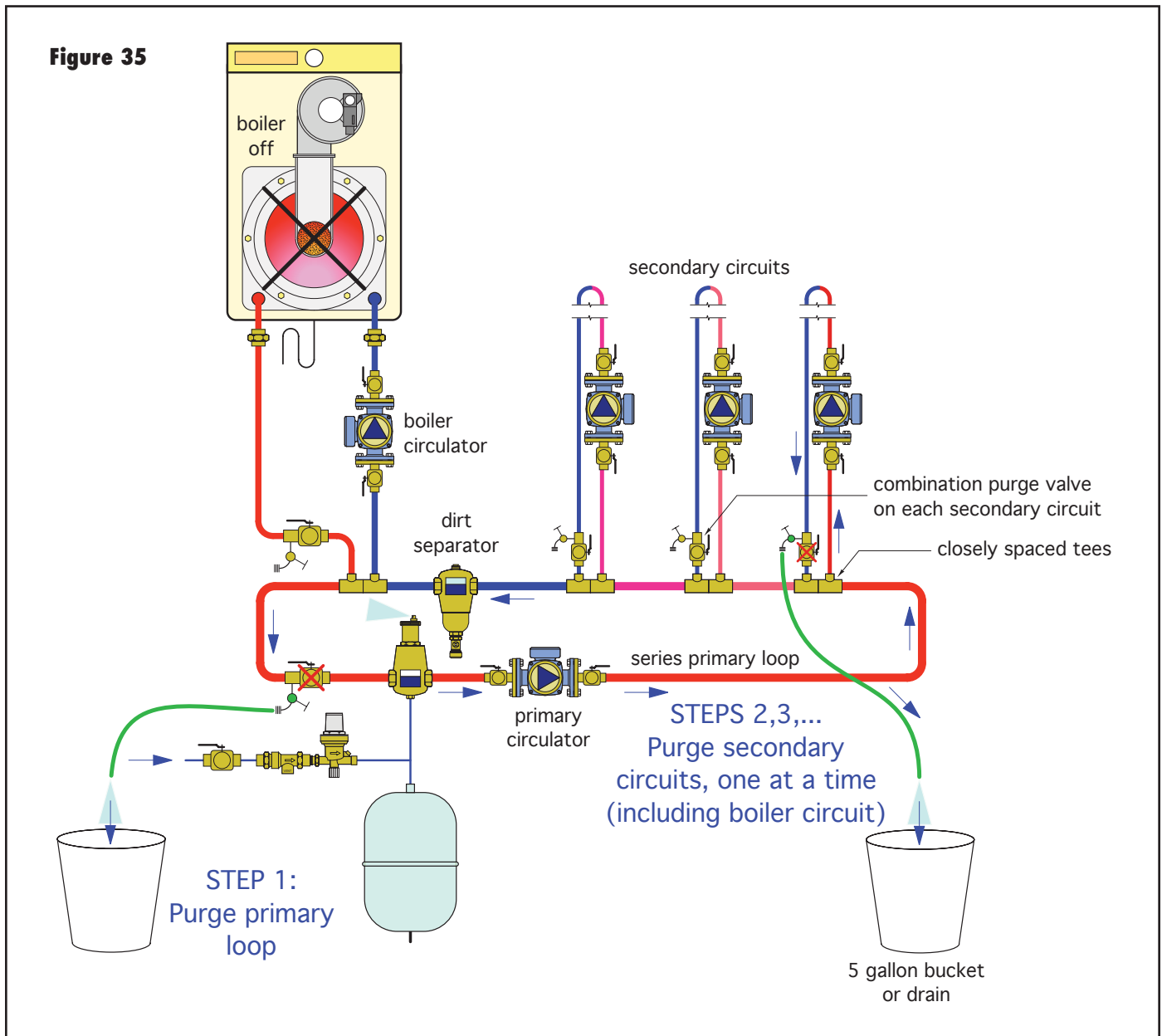

**Figure 36**

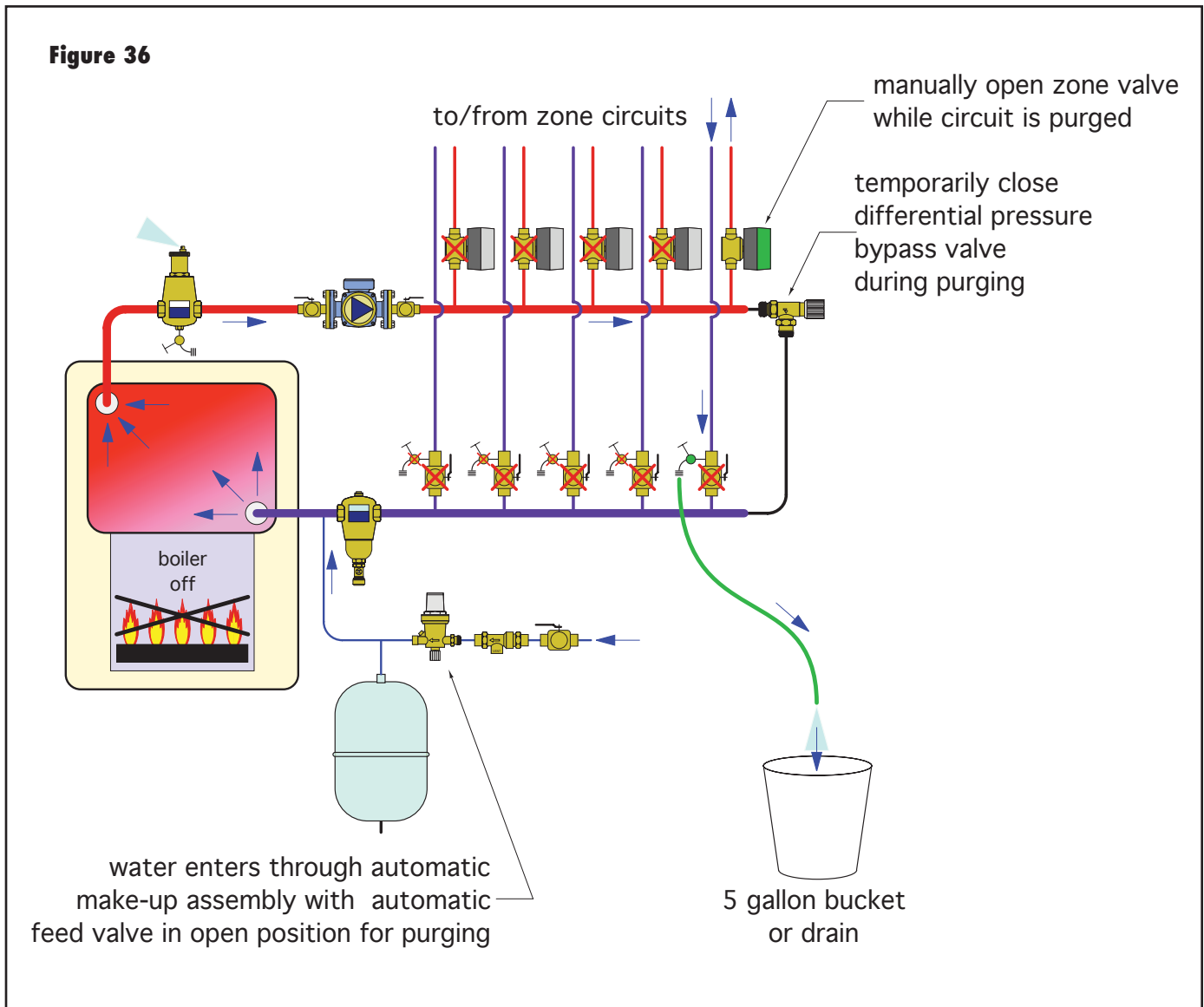

### DIAGNOSING AND CORRECTING AIR-RELATED PROBLEMS:

Properly designed and installed hydronic systems should operate for many years with virtually no detectable noise in occupied spaces. When noise does occur, it's often symptomatic of improper air control. This section describes some common noise complaints, provides possible causes, and gives suggested corrections. Keep in mind that some noises may be the result of a combination of these errors.

**Complaint #1:** *The system needs repeated "bleeding" to remove entrapped air.*

**Possible Cause:** The expansion tank is improperly located on discharge side of circulator.

**Description:** If the expansion tank is located on the discharge side of the circulator, the pressure in some

parts of the system may drop below atmospheric pressure while the circulator is on. If float-type air vents are located in these locations, air will be sucked into the piping. Air can also be sucked in through loose valve packings if the pressure at the valve goes sub-atmospheric.

**Corrective action:** This problem is resolved by relocating the expansion tank to the inlet side of the circulator. Two acceptable options for expansion tank placement are shown in figure 37. This modification has been very successful in many older systems, some of which had chronic air problems for years.

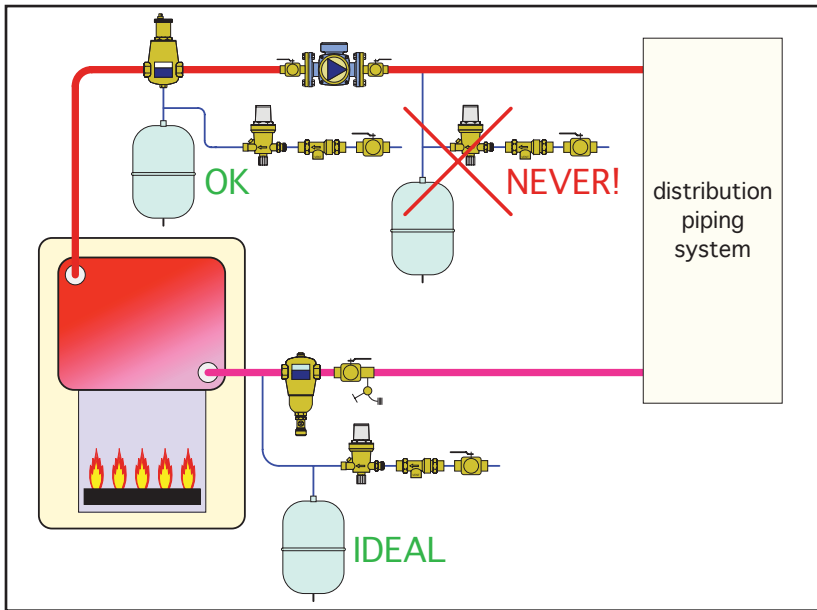

top of the system drops below atmospheric pressure, air can be drawn in through vents or valve packings. The automatic feed valve should be set to maintain a minimum static pressure of 5 psi at the top of the system.

A leak in the system can obviously lower pressure over time. Very minor leaks can be hard to identify. Look for external scaling on fittings, valves, or other locations where piping joints are made. Such scaling is a telltale sign of very slow but persistent water leakage.

**Corrective Actions:** Make sure the feedwater valve is adjusted to provide a minimum static pressure of 5 psi at the top of the system. Repair any leaks identified.

**Complaint #2:** The system pressure is always low and air is heard in piping.

**Possible causes:** Incorrect setting of the automatic make-up water assembly, or a leak.

**Description:** Low system pressure is often caused by not setting the automatic make-up water system properly or disabling it. If, for example, the shutoff valve on the make-up water line is closed, pressure will eventually drop due to very minor water loss at valve packings, or as air is removed by vents or the central air separator. If the pressure at the

**Complaint #3:** The system is quiet when circulation begins, but flow noises begin as the water heats up.

**Possible cause:** Air gases going in and out of solution but not being captured and ejected from the system.

**Description:** As described earlier, it's possible for air gases to go in and out of solution with water depending on temperatures and pressures. When water is heated, air comes out of solution as microbubbles. If these are not captured and ejected by a capable air separator, they will dissolve back into solution as soon as the system cools.

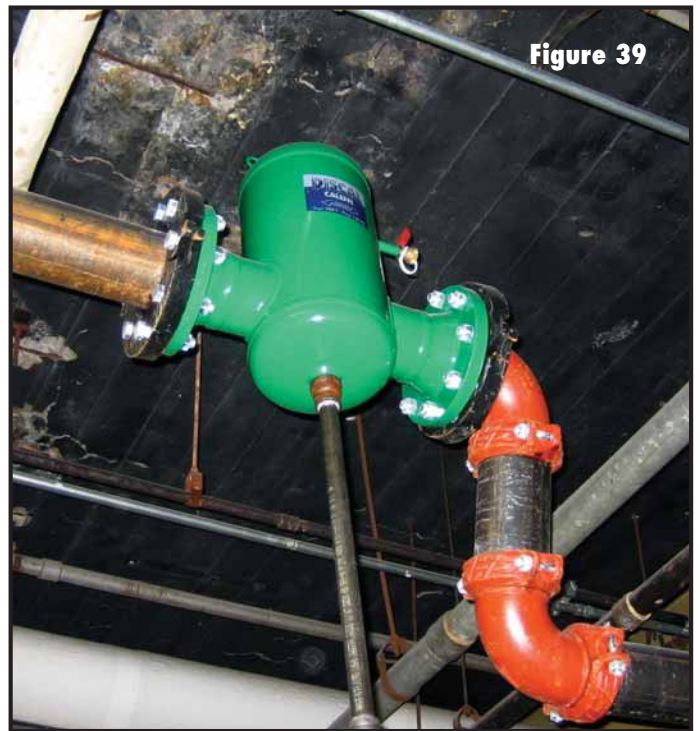



Figure 40

**Complaint #4:** Gurgling sounds are heard in piping.

**Possible cause:** Unentrained air bubbles.

**Description:** When persistent gurgling sounds are present, especially in piping with downward flow, it's likely the flow velocity in that portion of the system is too low to entrain the air and transport it to a central air separator.

**Corrective action:** All down-flowing piping should be sized to maintain a flow velocity of at least 2 feet/second to effectively entrain air bubbles. If this is not possible, automatic high point vents must be installed at locations where air can collect.

**Complaint #5:** Water drains out of piping in upper parts of the system every time the circulator turns off.

**Probable cause:** Air vents or leaks at the top of open-loop systems.

**Description:** This problem is often associated with unpressurized thermal storage tanks or unpressurized outdoor wood-fired furnaces. In such systems, the pressure above the water level in the tank or furnace drops below atmospheric pressure when the circulator stops. Air will try to enter the piping at any such point. Air vents located above the water level are the most likely entry points. However, valve packings, circulator flange gaskets, and even microleaks at threaded joints can admit air.

**Corrective action:** This type of system should not have air vents, valves, circulators, or even threaded fittings in any piping above the static water level in the tank or furnace. All piping should be designed for a flow rate of at least 2 ft./sec. to effectively entrain air bubbles and bring them back to the tank where they can be vented.



#### SUMMARY:

The ability of a hydronic system to provide efficient and silent conveyance of heat depends strongly on the condition of the fluid within the system. A well-designed hydronic heating or cooling system should rid itself of nearly all internal air shortly after commissioning. It should then operate with highly deaerated water, and virtually no noise will be detectable within occupied spaces.

Maintaining this high performance over the full design life of the system requires that internal surfaces on heat sources, heat emitters and circulators remain as clean as possible. Sediments or other debris flowing through the system are obviously detrimental to this goal and should be collected and expelled.

Caleffi offers system designers the highest quality air and dirt separation products available for these purposes in both large and small systems. The following photos show typical installations.

Figure 38 shows a small Caleffi Discal air separator being installed in a residential heating system.

Figure 39 shows a large Caleffi steel Discal air separator in service in a Milwaukee school. Piping at the bottom provides additional sediment drainage capability.

Figure 40 shows a small Caleffi Dircal dirt separator being installed in a residential system.

Figure 41 shows a Caleffi combination air/dirt separator being installed in a commercial cooling system.



# GENERIC COMPONENTS

# CALEFFI COMPONENTS

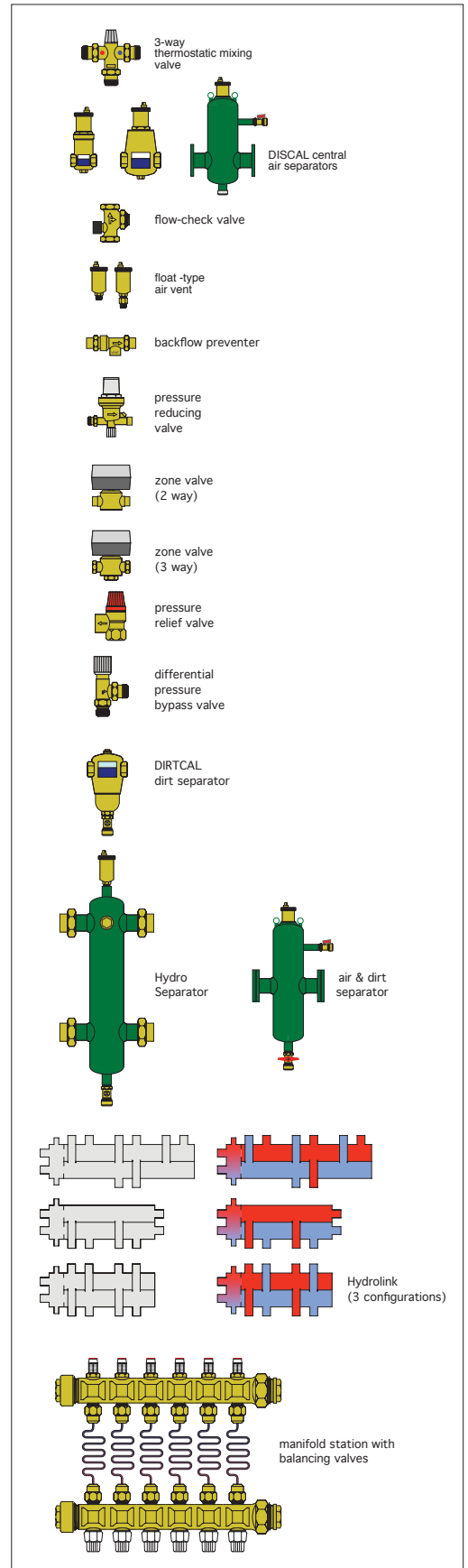
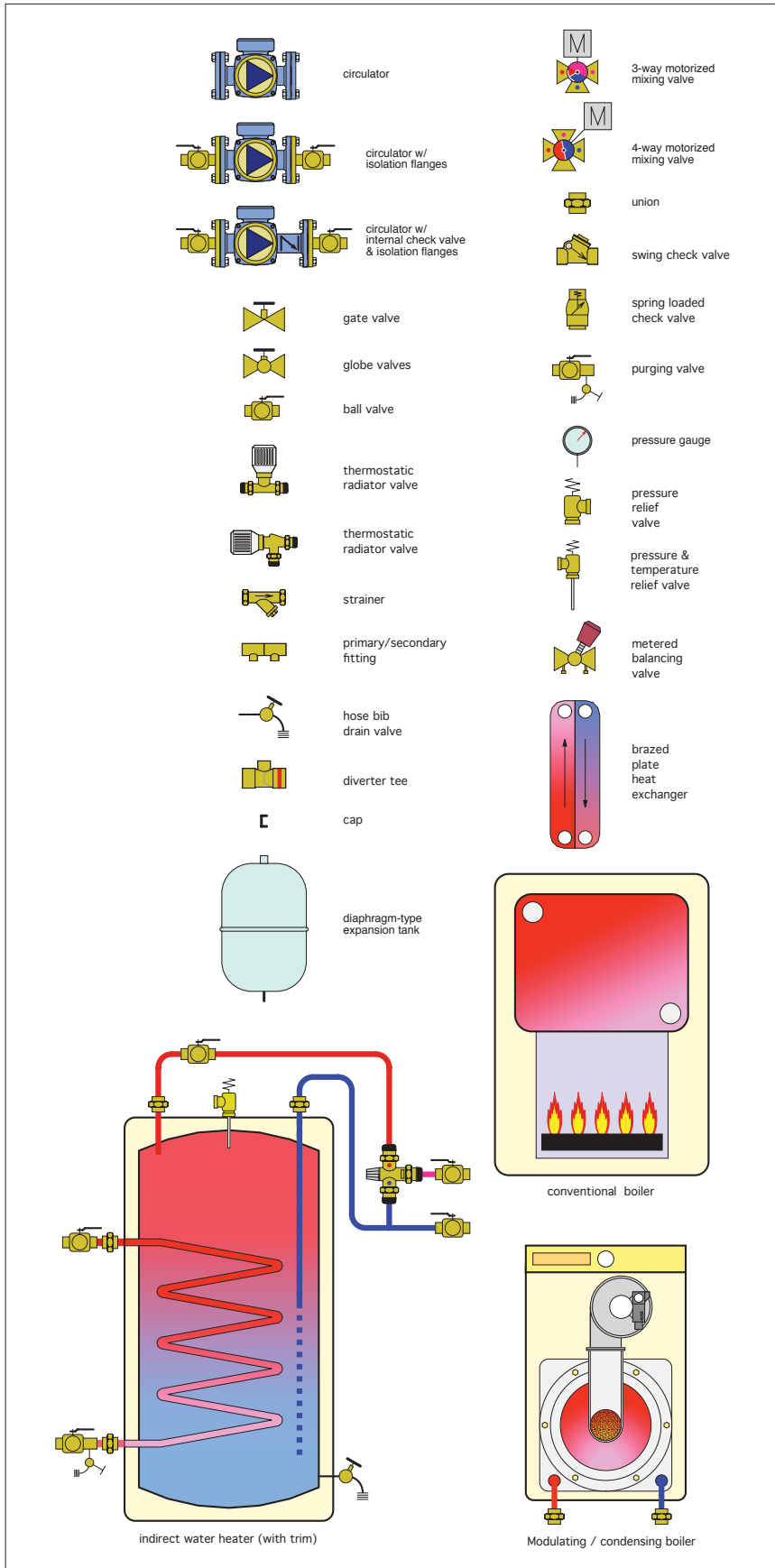

# DISCAL air separator

## series 551



### Function

Air separators are used to continuously remove the air contained in the hydronic circuits of heating and cooling systems. The air discharge capacity of these devices is very high. They are capable of removing automatically all the air present in the system down to micro-bubble level.

The circulation of fully de-aerated water enables the equipment to operate under optimum conditions, free from any noise, corrosion, localised overheating or mechanical damage.

### Product range

Series 551	DISCAL air separator in brass compact with drain	Sizes 3/4" sweat; 3/4" NPT female
Series 551	DISCAL air separator in brass with drain	Sizes 3/4" - 1" - 1 1/4" - 1 1/2" - 2" NPT female; 1" - 1 1/4" sweat
Series 551	DISCAL air separator in steel with flanged connections	Sizes 2" ÷ 6" ANSI
Series NA551	DISCAL air separator in steel with flanged connections designed and built to ASME	Sizes 2" ÷ 6" ANSI
Series NA551	DISCAL air separator in steel with threaded connections designed and built to ASME	Sizes 2" ÷ 4" NPT
Cod. 561402A	Service check valve in brass for easy replacement of expansion tank mounted to bottom drain	Size 1/2" NPT x 1/2" NPT

NA prefix indicates designed and built in accordance with Section VIII, Division 1 of the ASME Boiler and Pressure Vessel Code and tagged and registered with the National Board of Boiler and Pressure Vessel Inspectors.

### Technical specification

#### Brass Discal

Materials: - Body: brass  
- Int. element (compact version): stainless steel  
- Int. element: PA66GF30  
- Seal: EPDM

Suitable fluids: water, glycol solution  
Max percentage of glycol: 50%  
Max working pressure: 150 psi (10 bar)  
Temperature range: 32÷250°F (0÷120°C)  
Connections: - Main: 3/4" sweat; 3/4" NPT female  
3/4" - 1" - 1 1/4" - 1 1/2" - 2" NPT female  
1" - 1 1/4" sweat  
- Drain: 1/2" NPT female

#### Steel Discal

Materials: - Body: epoxy resin painted steel  
- Int. element: stainless steel  
- Drain cock: chrome plated brass  
- Seal: EPDM

Suitable fluids: water, glycol solution  
Max percentage of glycol: 50%  
Max working pressure: 150 psi (10 bar)  
Temperature range: 32÷250°F (0÷120°C)  
Connections: - Flanged: 2" ÷ 6" ANSI 150 CLASS  
- Threaded: 2" ÷ 4"  
- Drain: 1" NPT male

## Dimensions

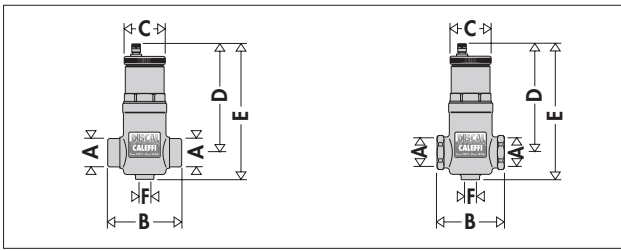

Code	A	B	C	D	E	F	Weight (lb)
551022A	3/4"	3 1/16"	2 3/16"	5 5/8"	6 7/8"	1/2"	2.0
551003A	3/4" swt	3 1/16"	2 3/16"	5 5/8"	6 7/8"	1/2"	2.0

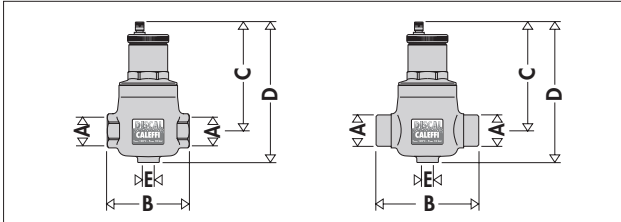

Code	A	B - B'	C	D	E	Weight (lb)
551005A	3/4"	4 5/16"	5 3/4"	7 1/2"	1/2"	3.7
551006A	1"	4 5/16"	5 3/4"	7 1/2"	1/2"	3.7
551007A	1 1/4"	4 7/8"	6 9/16"	8 1/4"	1/2"	4.9
551008A	1 1/2"	4 7/8"	6 9/16"	8 1/4"	1/2"	4.9
551009A	2"	5 1/8"	6 9/16"	8 1/4"	1/2"	4.9
551028A	1" swt	5 1/16"	5 3/4"	7 1/2"	1/2"	3.7
551035A	1 1/4" swt	5 3/16"	6 5/16"	8 1/4"	1/2"	3.7

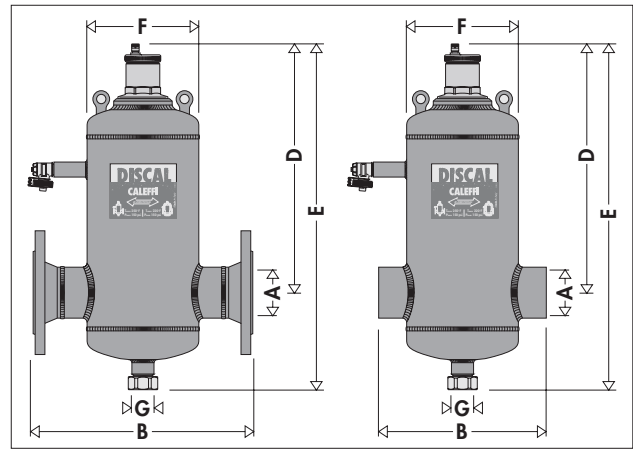

Code	A	B	D	E	F	G	Weight (lb)
551050A	2"	13 3/4"	14 3/4"	19 15/16"	6 5/8"	1"	33.1
551060A	2 1/2"	13 3/4"	14 3/4"	19 15/16"	6 5/8"	1"	34.2
551080A	3"	18 3/8"	17 1/8"	23 7/16"	8 5/8"	1"	61.7
551100A	4"	18 1/2"	17 1/8"	23 7/16"	8 5/8"	1"	66.1
551120A	5"	25	21 7/16"	30 1/2"	12 3/4"	1"	105.8
551150A	6"	25	21 7/16"	30 1/2"	12 3/4"	1"	116.8
NA551050T	2"	10 1/4"	14 3/4"	19 15/16"	6 5/8"	1"	20.5
NA551060T	2 1/2"	10 1/4"	14 3/4"	19 15/16"	6 5/8"	1"	21.0
NA551080T	3"	14 5/8"	17 1/8"	23 7/16"	8 5/8"	1"	44.0
NA551100T	4"	14 5/8"	17 1/8"	23 7/16"	8 5/8"	1"	46.3

Size	2"	2 1/2"	3"	4"	5"	6"
Cap. (gal)	1.8	1.8	4.8	4.8	13.7	13.7

Add prefix NA to flanged code number when ordering ASME tagged and registered with the National Board of Boiler and Pressure Vessel Inspector

## The process of air formation

The amount of air which can remain dissolved in a water solution is a function of pressure and temperature.

This relationship is governed by Henry's Law and the graph below demonstrates the physical phenomenon of the air release from water. As an example, at a constant absolute pressure of 30 psi (2 bar), if the water is heated from 65°F (18°C) to 170°F (75°C), the amount of air released by the solution is equal to 1.8 gallons of air per 100 gallons of water.

According to this law it can be seen that the amount of air released increases with temperature rise and pressure reduction. The air comes in the form of micro-bubbles of diameters in the order of tenths of a millimetre.

In heating and cooling systems there are specific points where this process of formation of micro-bubbles takes place continuously: in the boiler and in any device which operates under conditions of cavitation.

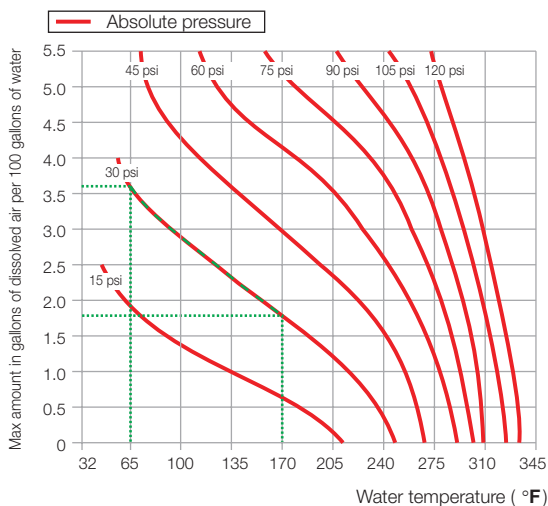

## Hydronic characteristics

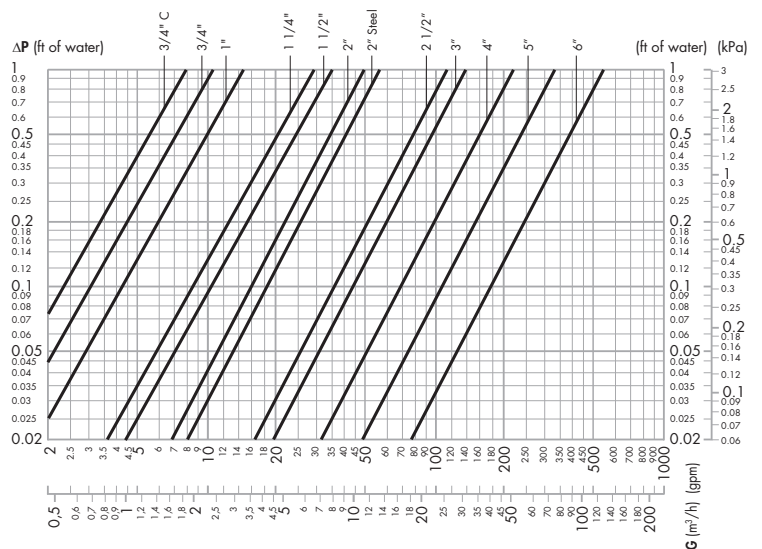

The fluid velocity at connections for Discal 551 series air separators is recommended to not exceed 10.0 f/s. Above this speed, heavy internal turbulence and noise can occur and air elimination efficiency begins to fall measurably. Optimal air elimination performance occurs at fluid velocities of 4.2 f/s or less. See the flow capacity chart.

	FLOW CAPACITY												
	Size	BRASS					STEEL						
		3/4" C	3/4"	1"	1 1/4"	1 1/2"	2"	2"	2 1/2"	3"	4"	5"	6"
Optimal (≤4.2 f/s)	GPM	6.0	8.0	9.3	15.3	23.9	36.1	37.3	63.0	95	149	259	380
	m <sup>3</sup> /h	1.4	1.8	2.1	3.5	5.4	8.2	8.5	14.3	21.7	33.9	58.8	86.2
Max. (10.0 f/s)	GPM	14.3	19.0	22.1	36.4	56.8	86.0	88.8	150.1	227.4	355.3	616.4	903.6
	m <sup>3</sup> /h	3.2	4.3	5.0	8.3	12.9	19.5	20.2	34.1	51.6	80.7	140.0	205.2
	Cv	14	19	21	43	51	78	86	179	211	345	520	809

# Dirt separator *DIRTCAL*

## 5462 series



### Function

In heating and air conditioning control systems, the circulation of water containing impurities may result in rapid wear and damage to components such as pumps and control valves. It also causes blockages in the heat exchangers, heating elements and pipes, resulting in a lower thermal efficiency within the system. The dirt separator separates off these impurities, which are mainly made up of particles of sand and rust, collecting them in a large collection chamber, from which they can be removed even while the system is in operation. This device is capable of efficiently removing even the smallest particles, with extremely limited head loss. Patented.

### Product range

5462 Series DIRTCAL dirt separator with NPT threaded connections \_\_\_\_\_ sizes 3/4"–1 1/2"  
 5462 Series DIRTCAL dirt separator with sweat connections \_\_\_\_\_ sizes 1" - 1 1/4"

### Technical specifications

Materials: - body: brass  
 - dirt collection chamber: brass  
 - top plug: brass  
 - internal element: PA66G30  
 - hydraulic seals: EPDM  
 - drain cock: brass

Medium: water, glycol solution

Max percentage of glycol: 50%

Max working pressure: 150 psi (10 bar)

Temperature range: 32 – 250° F (0 – 110°C)

Particle separation capacity: to 5 µm

Connections: - main: 3/4", 1", 1 1/4", 1 1/2" NPT  
 1" & 1 1/4" sweat  
 - top: 1/2" F with plug  
 - drain: 3/4" garden hose

### Dimensions

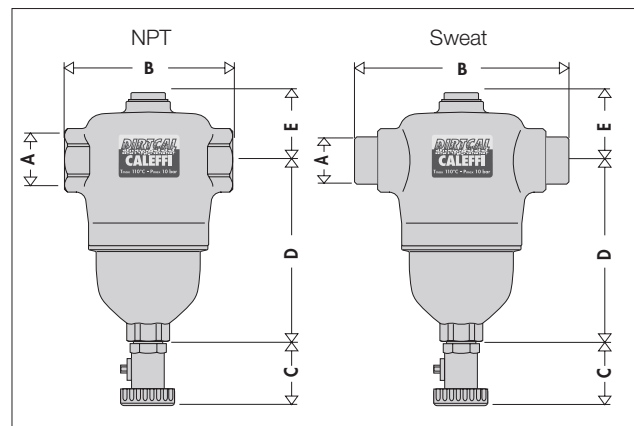

Code	A	B	C	D	E	Weight (lb)
546205A	3/4" NPT	4 5/16"	1"	5"	2"	4.2
546206A	1" NPT	4 5/16"	1"	5"	2"	4.2
546207A	1 1/4" NPT	4 7/8"	1"	6"	2"	5.3
546208A	1 1/2" NPT	4 7/8"	1"	6"	2"	5.3
546228A	1" Sweat	5 1/16"	1"	5"	2"	4.2
546235A	1 1/4" Sweat	5 3/16"	1"	5"	2"	4.2



## Hydronic characteristics

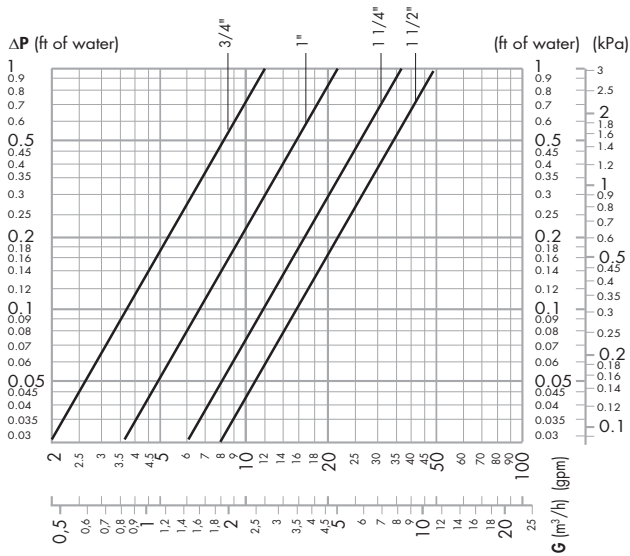

The maximum fluid velocity recommended at the unit connections is ~ 4.2 f/s. The following table shows the recommended flow rates to comply with this condition.

Size	3/4"	1"	1 1/4"	1 1/2"
Gpm	6	9.3	15.3	23.9
m <sup>3</sup> /h	1.36	2.11	3.47	5.42
Cv	18.8	32.6	56.6	73.3

## Separation efficiency

The capacity for separating the impurities in the medium circulating in the closed circuits of the systems basically depends on three parameters:

- 1) It increases as the size and mass of the particle increase. The larger and heavier particles drop before the lighter ones.
- 2) It increases as the speed decreases. If the speed decreases, there is a calm zone inside the dirt separator and the particles separate more easily.
- 3) It increases as the number of recirculations increases. The medium in the circuit, flowing through the dirt separator a number of times during operation, is subjected to a progressive action of separation, until the impurities are completely removed.

The Caleffi DIRTCAL dirt separator, thanks to the special design of its internal element, is able to completely separate the impurities in the circuit down to a minimum particle size of 5 µm.

The graph alongside, summarising the tests carried out in a specialised laboratory (TNO - Science and Industry), illustrates how it is able to quickly separate nearly all the impurities. After only 50 recirculations, approximately one day of operation, up to 100% is effectively removed from the circuit for particles of diameter greater than 100 µm and on average up to 80% taking account of the smallest particles. The continual passing of the medium during normal operation of the system gradually leads to complete dirt removal.

## Reduced head losses

A normal Y strainer performs its function via a metal mesh selected for the size of the largest particle. The medium therefore has a consequent initial loss of head that increases as the degree of clogging increases. Whereas, the dirt separator carries out its action by the particles striking the internal element and subsequently dropping into the collection chamber. The consequent head losses are greatly reduced and are not affected by the amount of impurities collected.

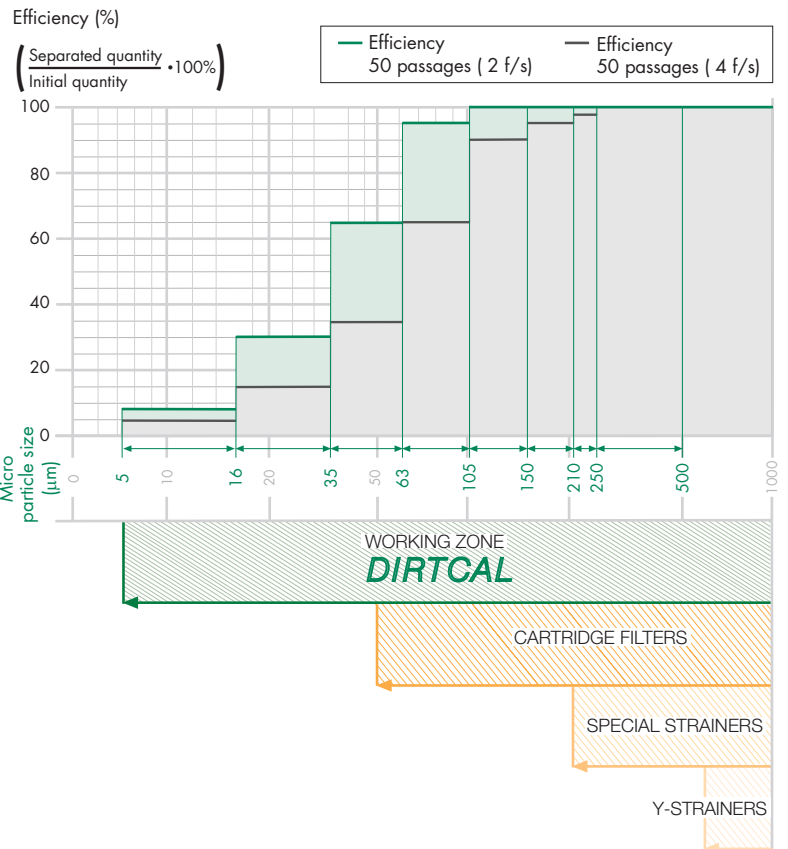

# DISCAL air and dirt separators

## series 546



### Function

Air and dirt separators are used to continuously remove the air and debris contained in the hydronic circuits of heating and cooling systems. The air discharge capacity of these devices is very high. They are capable of automatically removing all of the air present in the system down to the micro-bubble level. The Discal air/dirt separates any solid impurities in the system. The impurities collect at the bottom of the device and can be removed through the ball valve.

The circulation of fully de-aerated and cleaned water enables the equipment to operate under optimum conditions, free from any noise, corrosion, localized overheating or mechanical damage.

### Product range

- Series 546 DISCALDIRT air and dirt separator with ANSI flanged connections \_\_\_\_\_ sizes 2" - 6"
- Series 546 DISCALDIRT air and dirt separator with threaded connections \_\_\_\_\_ sizes 2" - 4"
- Series NA546 DISCALDIRT air and separator with ANSI flanged connections designed and built to ASME \_\_\_\_\_ sizes 2" - 6"
- Series NA546 DISCALDIRT air and separator with threaded connections designed and built to ASME \_\_\_\_\_ sizes 2" - 4"

NA prefix indicates designed and built in accordance with Section VIII, Division 1 of the ASME Boiler and Pressure Vessel Code and tagged and registered with the National Board of Boiler and Pressure Vessel Inspectors.

### Technical specification

- Materials:
  - Body: epoxy resin painted steel
  - Int. element: stainless steel
  - Drain valve: chrome plated brass
  - Release valve: brass
  - Seal: EPDM
- Suitable fluids: water, glycol solution
- Max percentage of glycol: 50%
- Max working pressure: 150 psi (10 bar)
- Temperature range: 32-250°F (0 - 121°C)
- Connections:
  - Flanged: 2" - 6" ANSI 150 CLASS
  - Threaded: 2" - 4"
  - Drain: 1" NPT female

### Dimensions

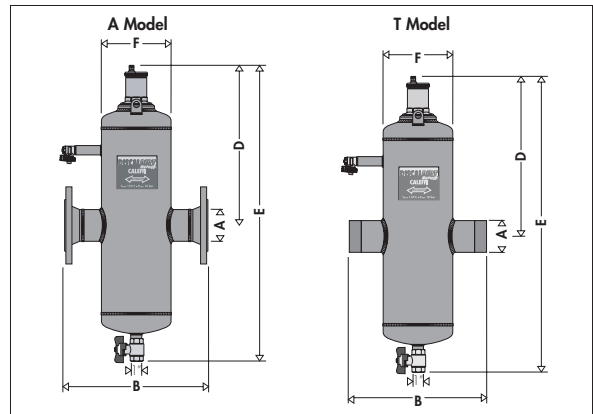

Code	A	B	D	E	F	Cap. (gal)	Weight (lb)
546 050A	2"	13 3/4"	14 3/4"	30 1/2"	6 5/8"	3.6	39.7
546 060A	2 1/2"	13 3/4"	14 3/4"	30 1/2"	6 5/8"	3.7	41.9
546 080A	3"	18 3/8"	17 1/8"	35 7/8"	8 5/8"	7.6	72.7
546 100A	4"	18 3/8"	17 1/8"	35 7/8"	8 5/8"	7.8	77.2
546 120A	5"	25"	21 5/16"	49"	12 3/4"	22.5	180.1
546 150A	6"	25"	21 5/16"	49"	12 3/4"	23	187.4
NA546 050T	2"	10 1/4"	14 3/4"	30 1/2"	6 5/8"	3.6	28.6
NA546 060T	2 1/2"	10 1/4"	14 3/4"	30 1/2"	6 5/8"	3.7	28.8
NA546 080T	3"	14 5/8"	17 1/8"	35 7/8"	8 5/8"	7.6	55.1
NA546 100T	4"	14 5/8"	17 1/8"	35 7/8"	8 5/8"	7.8	55.5

Add prefix NA to flanged code number for tagged and registered with the National Board of Boiler and Pressure Vessel Inspectors.

## Dimensions

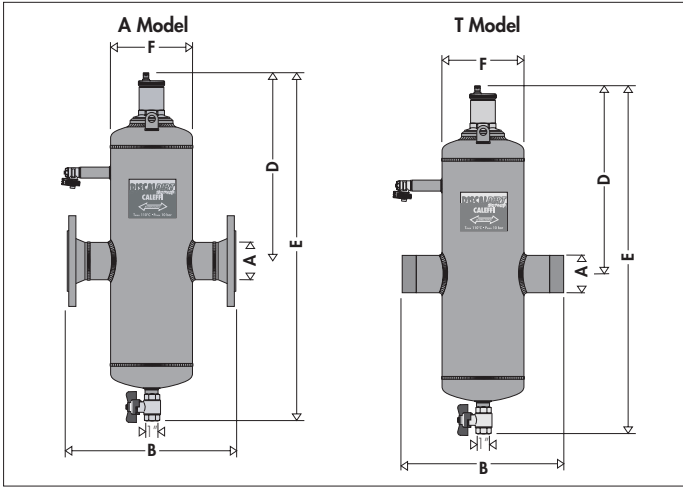

Code	A	B	D	E	F	Cap. (gal)	Weight (lb)
546 050A	2"	13 3/4"	14 3/4"	30 1/2"	6 5/8"	3.6	39.7
546 060A	2 1/2"	13 3/4"	14 3/4"	30 1/2"	6 5/8"	3.7	41.9
546 080A	3"	18 3/8"	17 1/8"	35 7/8"	8 5/8"	7.6	72.7
546 100A	4"	18 3/8"	17 1/8"	35 7/8"	8 5/8"	7.8	77.2
546 120A	5"	25"	21 5/16"	49"	12 3/4"	22.5	180.1
546 150A	6"	25"	21 5/16"	49"	12 3/4"	23	187.4
NA546 050T	2"	10 1/4"	14 3/4"	30 1/2"	6 5/8"	3.6	28.6
NA546 060T	2 1/2"	10 1/4"	14 3/4"	30 1/2"	6 5/8"	3.7	28.8
NA546 080T	3"	14 5/8"	17 1/8"	35 7/8"	8 5/8"	7.6	55.1
NA546 100T	4"	14 5/8"	17 1/8"	35 7/8"	8 5/8"	7.8	55.5

Add prefix NA to flanged code number for tagged and registered with the National Board of Boiler and Pressure Vessel Inspectors.

## Construction details

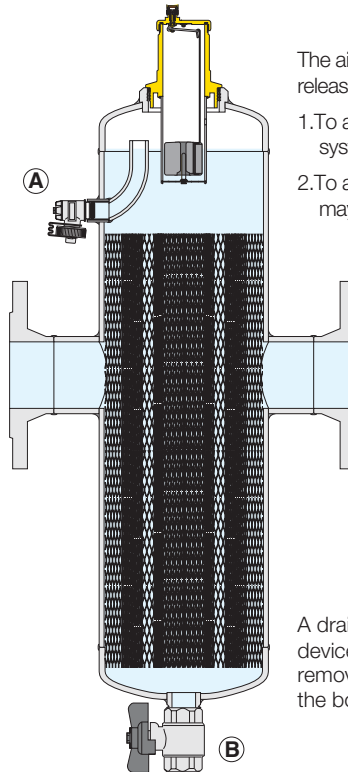

The air and dirt separator have an integral release point (A), which has two functions:

1. To aid the removal of air while filling the system during the
2. To aid the removal of any debris that may float within the air

A drain valve fitted to the base of the device (B) provides the capability to remove any debris that has settled at the bottom of the air eliminator.

## Boiler micro-bubbles

Micro-bubbles are formed continuously on the surface separating the water from the combustion chamber due to the fluid temperature.

This air, carried by the water, collects in the critical points of the circuit where it must be removed. Some of this air is reabsorbed in the presence of colder surfaces.

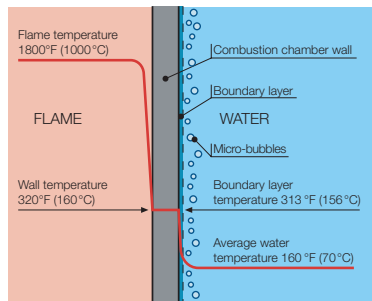

## Cavitation and micro-bubbles

Micro-bubbles develop where the fluid velocity is very high with the corresponding reduction in pressure. These points are typically the pump impeller and the regulating valve seating. These air and vapor micro-bubbles, the formation of which is enhanced in the case of non de-aerated water, may subsequently implode due to the cavitation phenomenon.

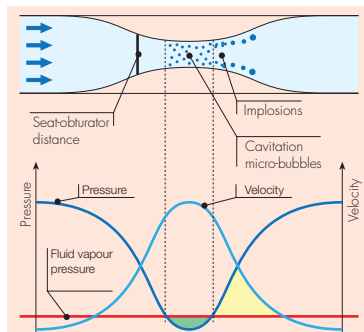

## Hydraulic characteristics

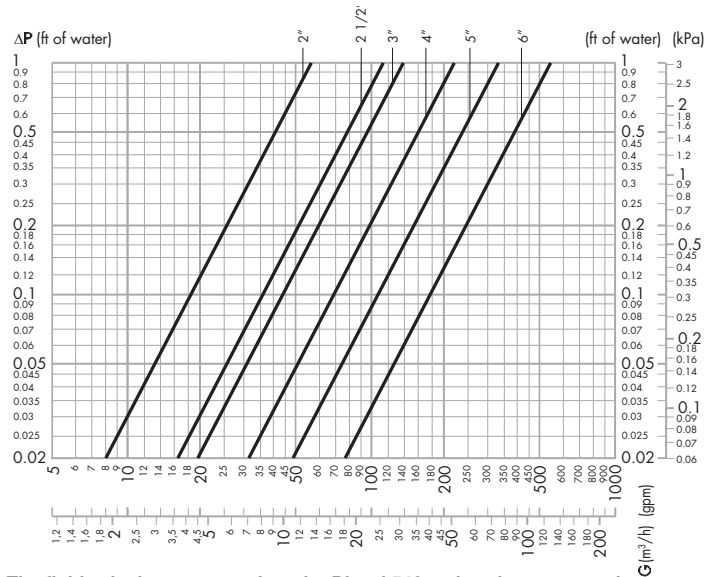

The fluid velocity at connections for Discal 546 series air separators is recommended to not exceed 10.0 f/s. Above this speed, heavy internal turbulence and noise can occur and air elimination efficiency begins to fall measurably. Optimal air elimination performance occurs at fluid velocities of 4.2 f/s or less. See the flow capacity chart.

		FLOW CAPACITY						
		Size	2"	2 1/2"	3"	4"	5"	6"
Optimal (≤4.2 f/s)	GPM	37.3	63.0	95	149	259	380	
	m³/h	8.5	14.3	21.7	33.9	58.8	86.2	
Max. (10.0 f/s)	GPM	88.8	150.1	227.4	355.3	616.4	903.6	
	m³/h	20.2	34.1	51.6	80.7	140.0	205.2	
	Cv	86	179	211	345	520	809	

# Automatic air vent for heating systems and radiators

series 501 - 5022 - 5026 - 5027 - 5080



## Function

**Series 501**  
Extra high capacity float type automatic air vent designed for use on large pipes where large quantity of air is required to be released from the system.

**Series 5022 - 5023**  
High capacity float type automatic air vent designed for use on manifolds or pipes in sealed heating systems. Check valve on 5023 series allows an easy replacement of air vent without purging the system.

**Series 5026 - 5027**  
Float type automatic air vent designed to vent air that is released from the water while being heated. Check valve on 5027 series allows an easy replacement of air vent without purging the system.

**Series 5080**  
Radiator air vent valve designed to remove automatically any air trapped inside the heat emitters both during the filling of the system and in normal operation.

## Product range

Series 501	Extra high capacity automatic air vent	_____	Size 3/4"
Series 5022	High capacity automatic air vent	_____	Size 1/2"
Series 5023	High capacity automatic air vent with check valve	_____	Size 1/2"
Series 5026	Automatic air vent	_____	Sizes 1/8" - 1/4"
Series 5027	Automatic air vent with check valve	_____	Sizes 1/8" - 1/4"
Series 5080	Automatic hygroscopic air vent for radiators	_____	Size 1/8"

## Technical specification

series ↔	501	5022 - 5023	5026 - 5027	5080
<b>Materials</b>				
Body:	brass	brass	brass	chrome plated brass
Float:	stainless steel	PP	PP	-
Mechanism stem:	stainless steel	brass	-	-
Mechanism seal:	Viton	EPDM	Silicon rubber	-
Seals:	EPDM	EPDM	EPDM	EPDM
<b>Performance</b>				
Max working pressure:	230 psi (16 bar)	150 psi (10 bar)	150 psi (10 bar)	150 psi (10 bar)
Max venting pressure:	90 psi (6 bar)	60 psi (4 bar)	90 psi (6 bar)	-
Max working temperature:	-4÷250°F (-20÷120°C)	250°F (120°C)	240°F (115°C)	212°F (100°C)
<b>Connections:</b>	inlet 3/4" NPT female exhaust 3/8" female straight	1/2" NPT male	1/8" and 1/4" NPT male	1/8" NPT male



**Dimensions**

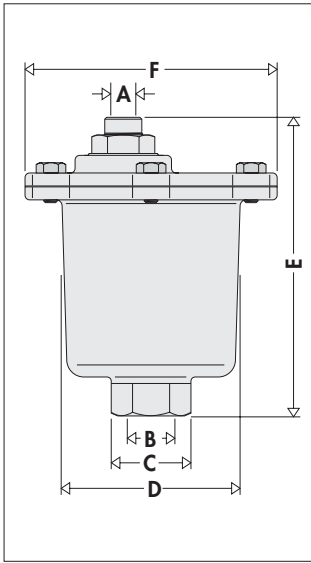

Code	A	B	C	D	E	F
501502A	3/8"	3/4"	1 9/16"	3 13/16"	6 1/4"	5 5/16"

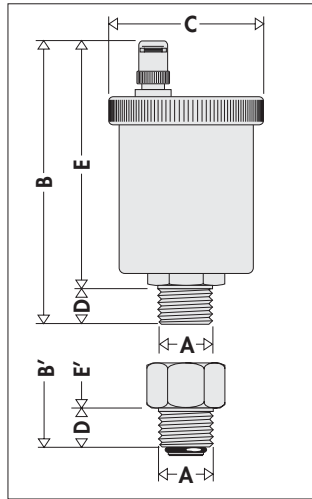

Code	A	B	C	D	E
502243A	1/2"	4"	2 3/16"	1/2"	2 1/2"

Code	A	B'	C	D	E'
502343A	1/2"	4 3/4"	2 3/16"	1/2"	3 1/4"

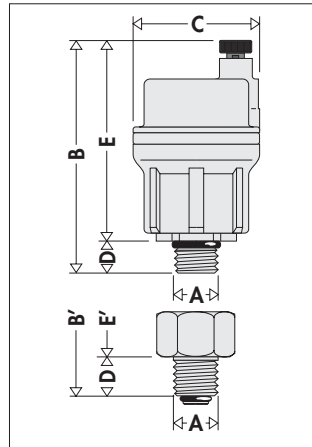

Code	A	B	C	D	E
502610A	1/8"	3 1/16"	1 9/16"	7/16"	2 5/8"
502620A	1/4"	3 1/16"	1 9/16"	1/2"	2 5/8"

Code	A	B'	C	D	E'
502710A	1/8"	4"	1 9/16"	1/2"	3 3/8"
502720A	1/4"	4"	1 9/16"	1/2"	3 3/8"

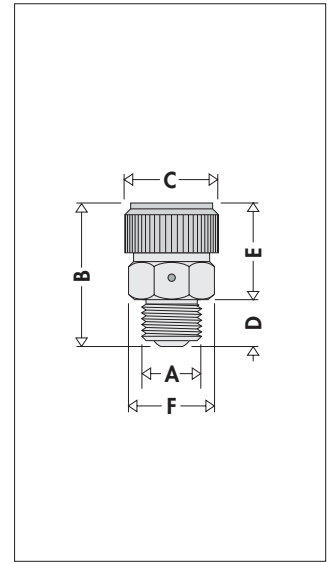

Code	A	B	C	D	E	F
508013A	1/8"	1 1/4"	1 1/16"	7/16"	13/16"	9/16"

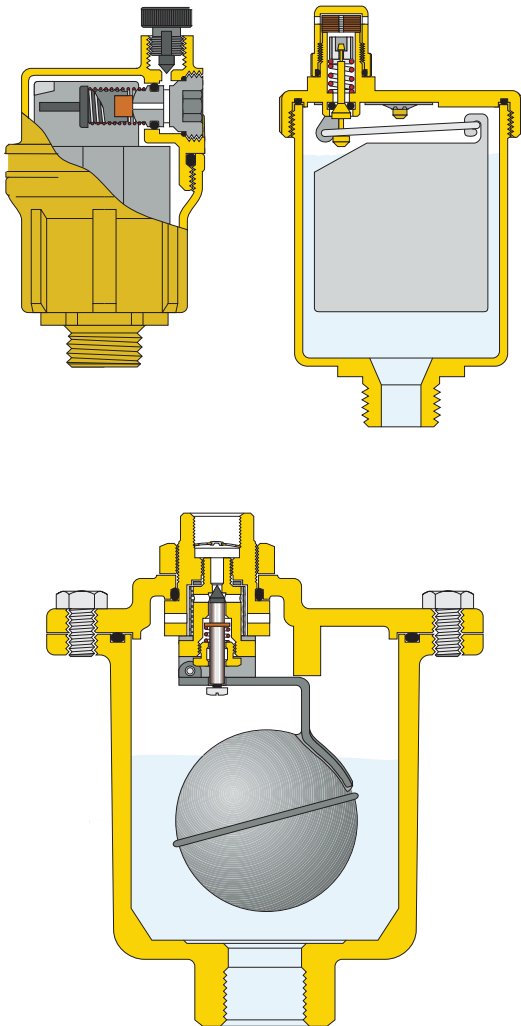

Valve code 5080 can be used manually or automatically. The **automatic** discharge is based on the property of the cellulose fibre discs forming the seal cartridge.

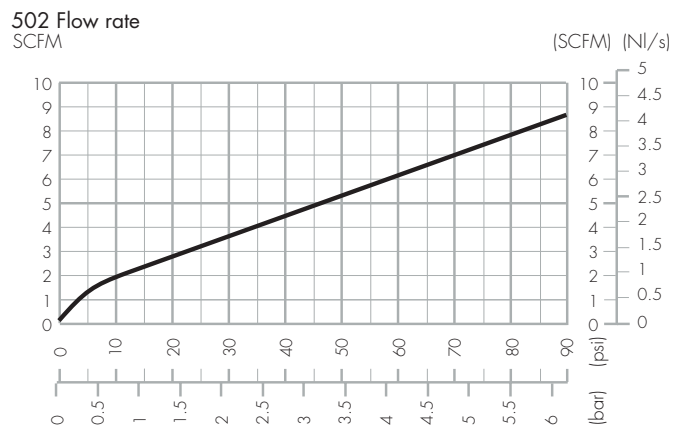
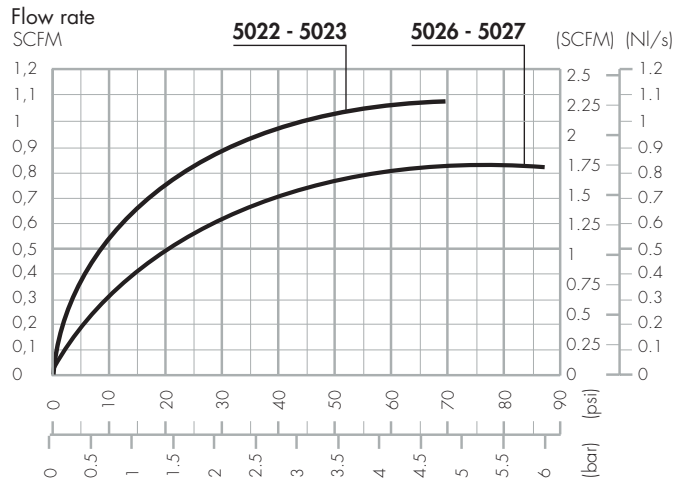
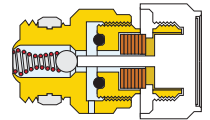

# Pre-adjustable filling units & backflow preventer

series 553 - 573



## Function

The automatic filling unit is a device consisting of a pressure reducing valve with compensating seat, an inlet filter, a shut-off valve and a check valve.

It is installed on the water inlet piping in sealed heating systems, and its main function is to maintain the pressure of the system stable at a set value, automatically filling up with water as required.

**This product has the characteristic of being pre-adjustable, which means that it can be adjusted at the required pressure value before the system charging phase.**

After installation, during the filling or topping-off phase, the water feed will stop when the set pressure is reached.

A pre-assembled version is also available, complete with upstream backflow preventer.



## Product range

Code 553542A	Filling unit with pressure gauge and pressure setting indicator	_____	Size 1/2"
Series 573	Backflow preventer with intermediate atmospheric vent with threaded connections	_____	Size 1/2" - 3/4"
Series 573	Backflow preventer with intermediate atmospheric vent with sweat connections	_____	Size 1/2"
Code 573002A	Charging unit complete with backflow preventer 573 series with threaded connections	_____	Size 1/2"
Code 573009A	Charging unit complete with backflow preventer 573 series with sweat connections	_____	Size 1/2"

## Technical specification

### Filling unit

Material: Body:	brass
Cover:	PA 66 GF 30
Seals:	NBR
Maximum Working Pressure:	230 psi (16 bar)
Pressure setting range:	3÷60 psi (0.2÷4 bar)
Factory setting:	15 psi (1.035 bar)
Indicator accuracy:	±2 psi (±0.15 bar)
Maximum Working Temperature:	150°F (65°C)
Connection: Inlet:	1/2" NPT Male with union tailpiece
Outlet:	1/2" NPT Female

### Backflow preventer

Material: Body:	brass
Check valve:	PSU
Check valve stem:	brass
Diaphragm:	EPDM
Seals:	EPDM
Maximum working pressure:	175 psi (12 bar)
Maximum working temperature:	210°F (99°C)
Medium:	water
Certified to:	CSA B64.3 and ASSE 1012
Connections:	1/2"-3/4" NPT female with union 1/2" sweat with union

## Dimensions

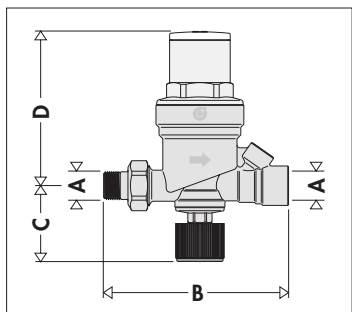

Code	A	B	C	D
553542A	1/2"	4 13/16"	1 15/16"	4"

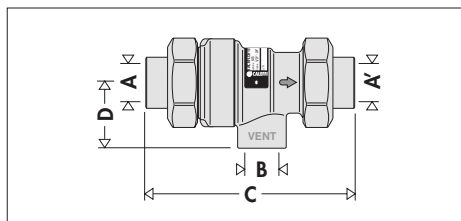

Code	A	A'	B	C	D
573403A	1/2"	1/2"	1/2"	4 1/2"	1 3/8"
573503A	3/4"	3/4"	1/2"	4 1/2"	1 3/8"
573409A	1/2" SWT	1/2" SWT	1/2"	4 7/16"	1 3/8"
573493A	1/2" SWT	1/2" NPT	1/2"	4 7/16"	1 3/8"

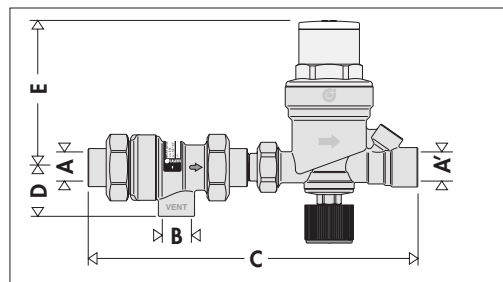

Code	A	A'	B	C	D	E
573002A	1/2"	1/2"	1/2"	9"	1 3/8"	4"
573009A	1/2" SWT	1/2" NPT	1/2"	8 15/16"	1 3/8"	4"

## Construction details

### Pre-calibration

This model is equipped with a pressure setting indicator for the commissioning operation. The system charge pressure can be input by means of the adjusting screw, before the start of the system charging phase.

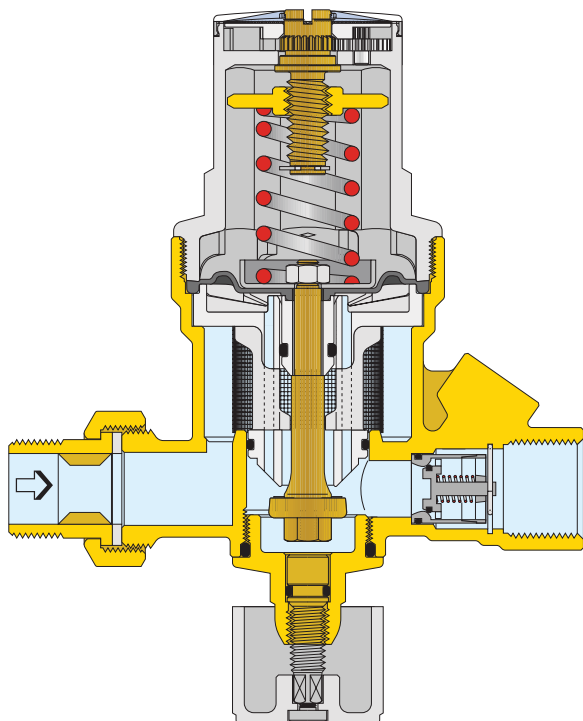

### Backflow preventer

The backflow preventer with atmospheric vent is designed to protect drinking water systems from the return, caused by backsiphonage or backpressure, of contaminated fluids.

The Caleffi 573 series has been specifically certified to standards CSA B64.3 and ASSE 1012.

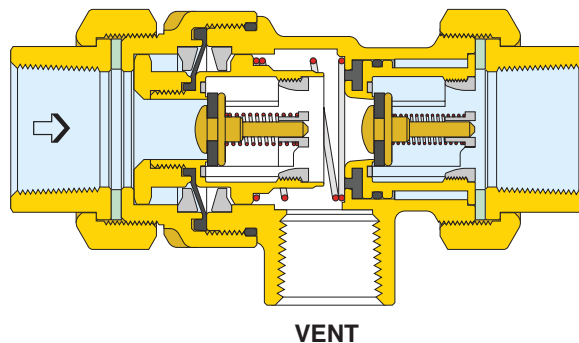

### Backflow preventer flow rate graph

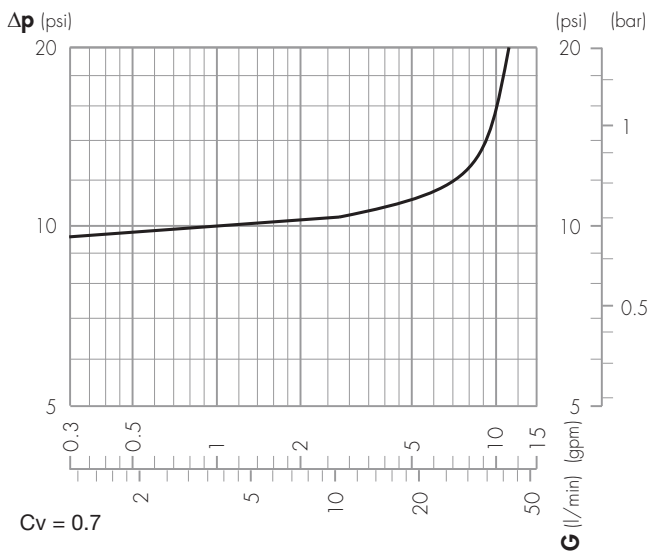

Code 573002A - 573009A

Charging unit consists of:

- Backflow preventer 573 series with atmospheric vent,
- Filling unit, 553 series

# MICRO-BUBBLE ELIMINATOR

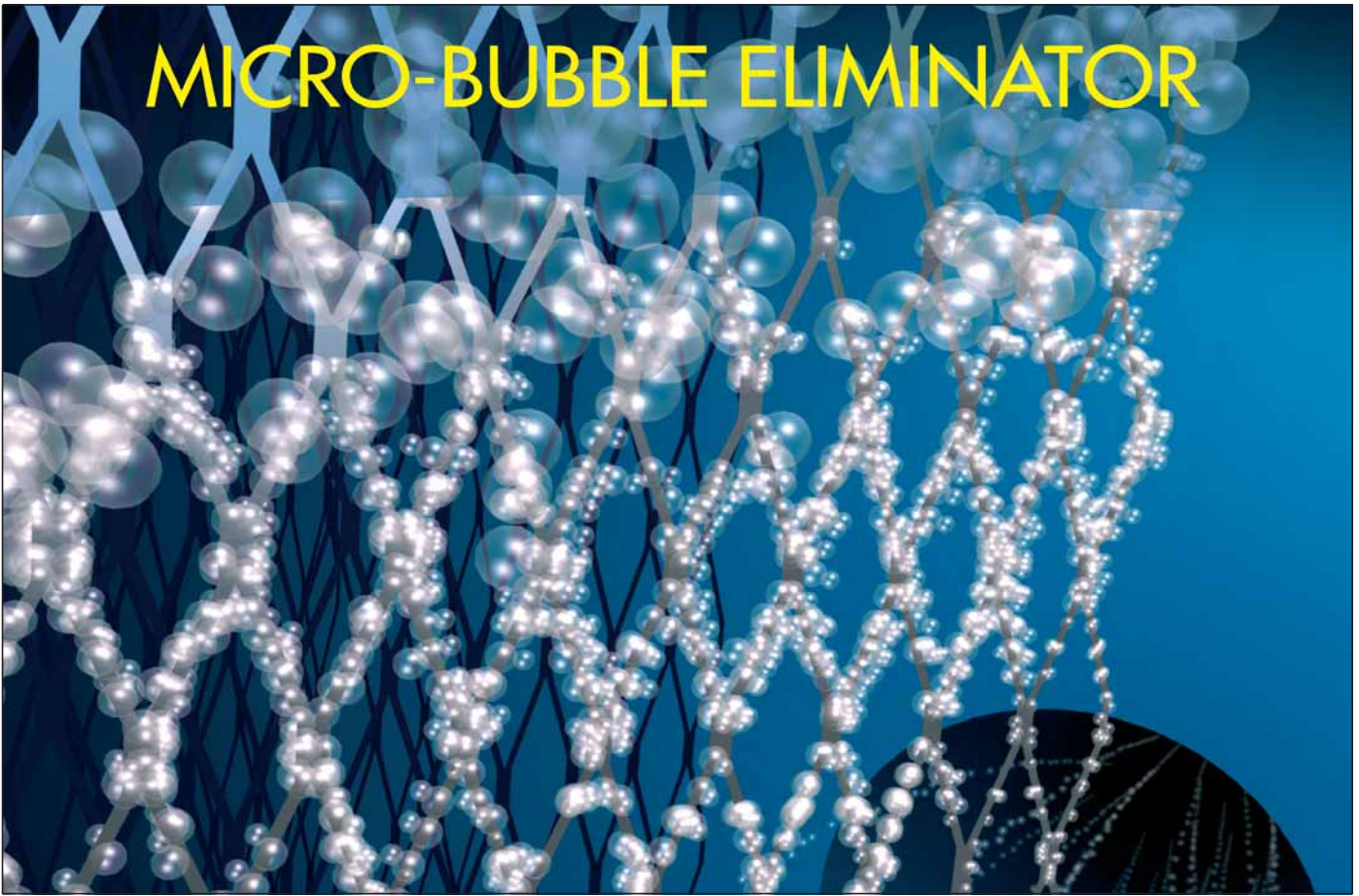

## Discal - Air Separator and Air & Dirt Separator

[www.caleffi.us](http://www.caleffi.us)

- Non-corrosive element efficiently removes corrosive, oxygen rich micro-bubbles
- Continuously removes the air and dirt in heating and chilled water systems
- Wide product range including sweat, threaded and flanged connections
- Built to ASME Boiler and Pressure Vessel Code, Registered with National Board

*Caleffi North America Inc. - Milwaukee, WI - Tel 414.421.1000 - sales@caleffi.com*

CALEFFI SOLUTIONS MADE IN ITALY

 **CALEFFI**  
Hydronic Solutions